

DIGILUBE PROGRAMMABLE LUBRICATION SYSTEM INSTALLATION/OPERATIONAL MANUAL

1.0 INTRODUCTION The Digilube Programmable Lubrication System is ideal for lubricating a wide variety of conveyors and machines. The DL-5002 Head Controller (HC) which controls the lubricator is the most technologically advanced, yet easy to use microprocessor in the industry. A large four line LCD screen and 16 button key pad provide on-screen instructions for programming the unit and adjusting the lubricator for your particular conveyor. This manual provides complete information needed to install, program, service and order replacement components for your system.

2.0 DESCRIPTION

2.1. The DL series of Digilube's programmable lubricators provide pinpoint accuracy of lubricant to many different types of conveyors' lube points. Typical areas of lubrication include chain pins, open trolley bearings, free carriers, swivels, cat drive chains, roller chain, etc.

2.2 Each system consists of a lubricator with a DL-5002HC and a pumping station (lubricant tank). The DL-5002HC is the brains of the system.. This programmable Head Controller has four (4) independent channels, with 24VDC outputs, four digit PIN security code, easy-to-read LCD screen, 16-button key pad...and much more.

2.3 The lubricator can be connected to several different size pumping stations. The DL-806 Pumping Station - 6 gallons can be mounted directly on the conveyor track in back of the lubricator, or remotely positioned waist high on a column for easy filling.

2.4 All Pumping Stations (DL-806, DL-812, & DL-865) can be supplied with or without a DL-9000 Power Supply (PS). This tank is designed to provide lubricant from a single source to multiple lubricators within a 700-foot radius. The DL-9000PS comes in either 115VAC or 24VDC output.

3.0 SPECIFICATIONS

3.1 LUBRICATOR WITH DL-5002HC

Dimensions/Weight

DL-5002HC (Head Controller)

Circuitry

Power Requirements

Operating Temperatures

Authorization Security Code

Memory

- Lubricator will vary depending on type of conveyor and/or if premounted.

- 15 lbs - 8" x 10"

- Solid state electronics, microprocessor controlled

- 115 VAC 3 Amps or 24 VDC 3 Amps

- 45° F minimum, 140° F maximum

- Four (4) digit, preset at factory to 0000

- EPROM

Lube Time (Volume Control)
Paint/Color

- Adjustable settings from 0001 to 9999
- Powder/Gray with Burgundy Logo

3.2 LUBRICANT TANKS

Capacity/Dimensions

- DL-806 - 6 gal 18 ½"H x 12 ½"W x 15"L
- DL-812 - 12 gal 22½"H x 12 ½"W x 15"L
- DL-865 - 65 gal, 49"H x 22 ½"W x 22 ½"L

Weight w/o DL-9000PS

- DL-806 – 60 lbs.
- DL-812 - 75 lbs
- DL-865 - 210 lbs

DL-9000PS/115 (Power Supply)

- 15 lbs - 8" x 10" 115 VAC output (Optional)

DL-9000PS/24 (Power Supply)

- 17 lbs - 8" x 10" 24 VDC output (Optional)

Circuitry

- Electromechanical timer, control relay and hard wire circuitry

Power Requirements

- 115 VAC, 10 AMPS

Pressure Gage/Filter

- Motor/Pump 115VAC, 1/3 Hp, 6 Amps

Lubricant Level

- 160 psi, liquid filled, in-line

Paint/Color

- Electronic sensor with red indicator on all tanks

Lubricant Viscosity

- Powder/Burgundy with gray logo

- Approx. range: 30 - 500 SSU at 100 F

4.0 SEQUENCE OF OPERATIONS

4.1 ALL PUMPING STATIONS WITHOUT DL-9000 PS. In the "OFF COUNT" mode, the channels' valve(s) will not operate, although the detection sensor will still operate. An LED indicator on the sensor will signify the sensor is operating properly. The supply tubing (nylon, steel, copper, etc) connecting the pumping station to the solenoid valves will have 20 - 25 psi of lubricant pressure. A check valve at the pumping station will maintain this psi in the "OFF COUNT" mode.

4.2 When a lubrication cycle is about to begin (actually 8 sensor activation's prior to operation), the pump/motor will start and maintain lubricant pressure to the valve(s) throughout the lubrication cycle. Each time a sensor is activated, the valve will dispense lubricant onto the desired point(s). After completion of the lubrication cycle, the valve(s) will deactivate to normally closed. The pump/motor will continue to run for approximately five minutes (5) and shut off.

4.3 During a lubrication cycle, if the conveyor stops, the pump/motor will run for approximately five minutes (5) then shut off. Once the conveyor restarts and the channels sensor activates the pump/motor will restart.

4.4 If the pumping station's lubricant level runs low, the pump/motor will also shut off and the red indicator lamp will turn on at the DL-5002HC. Once the pumping station is refilled with lubricant, the lamp will turn off, the pump/motor will turn on and the DL-5002HC will resume its

lubricating cycle where it left off in the "ON COUNT" mode. **Note: If intermittent power loss occurs, the DL-5002HC will retain its memory count in the program.**

4.5 ALL PUMPING STATIONS WITH DL-9000 POWER SUPPLY (PS). The DL-9000PS is designed to be trouble free and easy to install. Once the electrical connection is made and the Low Pressure level Switch and High Pressure Level Regulator settings are adjusted, the DL-9000PS functions automatically.

4.6 The DL-9000PS supports three peripherals. A Low Pressure Level Switch (LPLS), a High Pressure Level Regulator (HPLR), and a low level switch. The LPLS turns on the pump/motor when the lubricant pressure in the supply tubing drops to its **Lowest PSI** setting. The HPLR maintains the lubricant pressure in the supply tubing to its **Highest PSI** setting. The low level switch prevents the pump/motor from running and allowing air into the line

4.7 All Digilube Pumping Stations are designed for use with **"THIN FILM LUBRICANTS ONLY"**. When using THIN FILM lubricants, the HPLR is factory-set between 25 - 35 PSI, depending on the length and elevation of supply tubing from the pumping station to the lubricator(s) and the number of solenoid valve(s) in the system. The LPLS is set 8-10 PSI lower than the HPLR.

4.8 When all channels in the system are in the "OFF COUNT" (NON-LUBRICATION) mode the pump/motor is off. The lubricant pressure in the supply tubing is maintained at the HPLR setting of 25 - 35 PSI by a check valve at the pumping station. The solenoid valve(s) will not be operating although the LED sensor(s) will be counting each detection.

4.9 When a channel's "OFF COUNT" reaches 0000, it goes into a lubrication cycle. As the valve(s) open and close, the lubricant pressure in the supply tubing begins to drop. Once it reaches the LPLS setting the pump/motor turns on. The pump/motor will continue to run until the HPLR setting has been maintained for 25 minutes. Once this occurs, the pump/motor will turn off, indicating that the solenoid valve(s) have been closed for that period of time.

4.10 The pump/motor will also turn off if the pumping station runs out of lubricant and a red indicator lamp on the DL-9000PS turns on. Filling the pumping station will automatically restart the pump/motor and turn off the red lamp.

4.11 Once the pump/motor shuts down one of three situations are present: the channel(s) on the DL-5002HC have completed their lubricant cycle(s), the conveyor has stopped, or the fluid level in the pumping station is low.

5.0 INDICATOR LAMPS

5.1 GREEN/CLEAR LAMPS

Indicates power to the DL-5002HC or DL-9000PS. This lamp will be on at all times, except during power loss..

5.2 YELLOW LAMPS

Indicates the pump/motor is running and a request for lubricant from a lubricator has occurred.

5.3 RED LAMP

Indicates the pumping station is out of lubricant. The red lamp also indicates the pump/motor have automatically shut down to prevent air from getting into the supply tubing. The red lamp will automatically turn off and the pump/motor will restart when the pumping station is refilled.

NOTE: The red lamp on the DL-5002HC does not operate when used with a DL-9000PS. The red lamp on the DL-9000PS will operate along with the green/clear and yellow lamps. Optional rotating tower indicators are also available.

6.0 INSTALLATION

6.1 SITE SELECTION

The best location for a lubricator on a conveyor with a washer/oven is on a straight level section of rail between the load and unload area as usually there are no parts in this location. However many times the load & unload area is the same place and where people are working. The next best location would be after the raw parts are loaded before the washer. If lubricant does drip on a part it is washed off prior to painting.. It is very important that the conveyor chain be properly protected in the washer.

6.2 Mount at a point on the conveyor that ensures chain stability and that the chain is under tension.

6.3 Vibration should be minimal and bearings should be rolling as they pass the lubricator.

6.4 Avoid unstable or hazardous environments like high temperatures, water or chemical exposure.

6.5 We recommend that the DL-806 & DL-812 pumping stations be located on a structural column waist high for ease of filling, out of high traffic fork truck areas. When using a pumping station with multiple lubricators, centralized the pumping station within the circumference of the lubricators.

7.0 MOUNTING THE LUBRICATOR

7.1 An enclosed track lubricator comes mounted on a track rack and a monorail I-Beam lubricator comes premounted on a track section for ease of installation. The lubricator can also be installed on the customers' existing conveyor and is usually done by a contractor or a Digilube Systems Service Representative.

7.2 Once the location has been determined, cut and weld the premounted track section in place or modify the existing conveyor track section.

7.3 Power Connections information, see 10.0., diagrams & illustrations at **18.1 -18.9.**

8.0 MOUNTING DL-806 & 812 PUMPING STATIONS

8.1 DL - 806 PUMPING STATION

The DL-806 can be installed on conveyor rail right behind the lubricator or at a remote location for ease of filling. For other pumping stations please refer back to **6.5**

8.2 If the DL-806 Pumping Station is mounted with the lubricator, weld premounted track section in place and connect to 115VAC, 10 AMP continuous power source to the DL-5002 Head Controller. See electrical diagram **18.2.**

8.3 For remote installation, locate tank as mentioned in **6.5. All pumping stations w/o DL-9000PS require that the power source (115vac) be run from the lubrication head back to the pumping station. Refer to 18.2** When installing nylon tubing push the tubing firmly and as far as possible into the quick-connect fitting located next to the motor on the tank. Make sure the proper connection is made by pulling back on the tubing. This will lock-in the tubing. The supply tubing can be secured to the electrical conduit connecting the pumping station to the lubricator with wire ties. The tubing can also be connected to overhead building structural members with wire ties or beam clamps. Sharp bends in the supply tubing will slow or stop lubricant flow and must be avoided. To remove the tubing, push in on the fitting collar while pulling out on the tubing. The self-locking fitting is reusable. The nylon tubing is usually 1/4" O.D. However, steel or copper tubing should be used for high-temperature service, which will require different fittings. See lubricatorl diagram **18.0.**

8.4 If there is power to the DL-5002HC the red lamp will be on. Once the pumping station is filled with lubricant the red lamp will turn off.

9.0 MOUNTING PUMPING STATIONS WITH DL-9000PS (OPTIONAL)

9.1 Locate the pumping station in a protected area to avoid damage. **Please refer back to 6.5**

The DL-9000PS Power Supply must be connected to the incoming 115VAC, 10 AMP power source. See diagram & illustrations **18.6 - 18.7.** For remote installation, locate the pumping station as mentioned in **6.5. When installing nylon tubing** push the tubing firmly and as far as possible into the quick-connect fitting located on the top of the pumping station. Make sure the proper connection is made by pulling back on the tubing. This will lock-in the tubing. Run the supply tubing and power cable (only with DL-9000/24vcd) to each lubricator. Avoid sharp bends in the supply tubing as this will slow or stop lubricant flow. To remove the tubing, push in on the fitting collar while pulling out on the tubing. The self-locking fitting is reusable. The nylon tubing is usually 1/4" O.D. However, steel or copper tubing should be used for high-temperature service, which will require different fittings. See lubricatorl diagram **18.0.**

9.5 The LPLS is set at the factory to match the HPLR setting.. Should the pressure loss drop to the LPLS setting, it will close and signal the DL-9000PS to start the pump/motor. The LPLS setting must be checked and possibly changed if the HPLR setting is changed.

9.6 To adjust the LPLS, turn the thumb wheel clockwise to increase pressure loss required to start the pump/motor. Turn the thumb wheel counterclockwise to decrease the pressure loss required to start the pump/motor. You may test the LPLS adjustments by leaving one lubricator in a lubrication mode and observe the pressure gauge at the lubricant tank. When the pump/motor is operating and the desired high pressure is reached, push the "System Reset" toggle inside the DL9000PS. If the adjustment is correct, the pump/motor will not start until the pressure drops to LPLS setting which will then start the pump/motor. If it does not turn the pump/motor off, turn the thumb wheel clockwise to increase the pressure loss required to start the pump/motor.

10.0 POWER CONNECTIONS

10.1 DL-806 PUMPING STATION - 6 GALLON CAPCITY MOUNTED W/ LUBRICATOR

Connect incoming power to hot, neutral, and ground to J19 on the DL-5002HC's terminal strip. See diagram **18.2**.

10.2 ALL PUMPING STATIONS W/O DL-9000 PS CAPCITY FROM A REMOTE LOCATION

If the pumping station is installed at a remote location, run five (5) 14 gauge wires (1 black, 1 white, 1 green, 2 red) from the DL-5002HC to the motor and float. At the DL-5002HC's terminal strip,. the black and white wires connect to J13 and the two red wires connect to J7. At the Tank, connect the two red wires to the two yellow float switch wires. Connect the black and white wires to the motor leads for **low voltage - 115 VAC**. Connect incoming power to hot, neutral, and ground to J19 on the DL-5002HC's terminal strip. See diagram **18.2**.

10.3 ALL PUMPING STATIONS WITH DL-9000PS

The **DL-9000PS 115VAC** output is standard. An optional **DL-9000PS/24VDC** is also available. Both Power Supplies require a continuous 10 AMP 115VAC power source. Please consult Digilube System to determine which method is best for your conveyor..

10.4 DL-5002HC INPUT REQUIREMENTS CONNECTED TO DL9000PS/115VAC

When using a pumping station with a DL-9000PS/115VAC, no electrical connection is required between the DL-5002 and the pumping station. However a 115VAC 10 amp drop is required to each DL-5002.

10.5 DL-5002HC INPUT REQUIREMENT CONNECTED TO DL-9000PS/24 VDC

Electrical connects between DL-5002HC and DL-9000PS/24VDC output is as follows: Connect two strand 18 gauge shielded wire to J18 on DL-5001HC's terminal strip and to 11 & 12 on DL-9000PS/24 VDC's terminal strip. See diagrams & illustrations at **18.8, 18.,9**.

10.6 OPTIONAL AIR ASSIST DL-5002HC

Requires a minimum of 35 PSI and a maximum of 60PSI of air.

11.0 DL-5002HC DEFINITIONS

The Digilube system is controlled by the DL-5002HC. This microprocessor-based circuitry has four (4) independent channels which provide the user with the ability to insert the desired lubrication settings and to change settings whenever required while in the field. The DL-5002HC will automatically read these settings and incorporate them into its' performance.

11.1 "LINK MODE" DEFINITION

There are two ways of programming the DL-5002HC, either by LINK or by TIME. The LINK mode is used with a detection sensor. The sensor reads objects which pass in front of it like trolley wheels, chain pin links, rollers, etc. In a lubrication cycle, the sensor, when activated, will open up a solenoid valve and dispense lubricant. In both lubrication and non-lubrication modes, the sensor will count the number of objects which will then be processed by the DL-5002HC. Once programmed, the DL-5002HC will input these detections and lubricate accordingly.

11.2 "TIME MODE" DEFINITION (USED ONLY IN MACHINE & HIGH SPEED APPLICATIONS)

The TIME mode is used without any sensors. It functions on TIME only. The user determines when and how much lubricant will be dispensed at a given lube point. This mode is used on high speed chains, stationary lube points like sprockets and on machines.

11.3 "OFF COUNT" DEFINITION

In the LINK mode, the "OFF COUNT" means the number of complete revolutions the conveyor makes in a non-lubrication mode. EXAMPLE: An off count setting of 0002 the conveyor will make two (2) complete revolutions in without lubrication and then one (1) revolution with lubrication.

11.4 "ON COUNT" DEFINITION

The "ON COUNT"(LINK & TIME mode) means the total number of trolley wheels, center links, rollers, etc that make up a complete cycle of the conveyor. This is also the number of lubrication activations which will occur in the during a lubrication cycle of the program. When a lube cycle begins, the "OFF COUNT" is at zero (0000). In the TIME mode, this also corresponds to the number of shots of lubricant in the lube cycle.

11.5 TO DETERMINE "ON COUNT" FOR ENCLOSED TRACK CONVEYORS

Take the total length of the conveyor and multiply by 12, then

DIVIDE BY 6 FOR Richard-Wilcox conveyors

DIVIDE BY 8 FOR Rapid Flex & Jervis B Webb conveyors

For Rapid Flex & Jervis B Webb Systems using 4 wheel attachments additional counts will need to be figured in for CHANNEL #1 ONLY

11.6 "VALVE SETTING" DEFINITION

This determines the amount of time the solenoid valve(s) will be open. The longer the valve is open the more lubricant will be dispensed. A setting of 0000 is off. A 0.001 is required for the

valve to function properly and will dispense the least amount of lubricant and a 9.999 will dispense the largest amount.

EXAMPLE SETTINGS: **Please keep in mind every conveyor and application is different.**

The settings listed below are good starting points

CH#1	VERTICAL TROLLEYS	0001
CH#2	GUIDE ROLLER AND PIVOT POINTS	0001

11.7 “DEBOUNCE TIME” DEFINITION

The DEBOUNCE TIME indicates the amount of time the DL-5002HC will not accept another input from the detection sensor, thus preventing multiple shots of lubricant at the points to be lubricated. Generally a setting of 0500 or .5 sec will be sufficient however, when sensing an irregular casting or multiple wheels (such as a free trolley carrier) this setting will need to be increased to cover the entire field of the object.

11.8 “FEET PER MINUTE” DEFINITION

The CONVEYOR SPEED provides a digital read-out on the main screen of how many feet per minute the conveyor is traveling. You simply input the number of detections per foot and the DL-5002HC will calculate it automatically.

11.9 “OZ/LUBE CYCLE” DEFINITION (USED ONLY ON MACHINE LUBRICATION)

OZ/LUBE CYCLE provides a digital read-out on the main screen of how much lubricant is being used for one complete lubrication cycle. This is calculated by selecting the value from the chart at **20.0**. This is based on the channel’s TOTAL NUMBER OF “ON COUNTS”, “LUBE TIME”, LUBRICANT PSI AT SOLENOID VALVE, VALVES, DISPENSING TUBES AND SIZE..

11.10 “CONFIGURE MODE” DEFINITION

THE CONFIGURE MODE allows the user to change the four digit PIN security code This number keeps unwanted changes to the programmed settings. This mode also allows user to change the real-time clock for the TIME mode portion of the DL-5002HC. This allows for time zone differences, and time drift over a period of years. This mode can also change the baud rates(ASCII COMMUNICATION) if an optional modem is used.

11.11 “TEST MODE” DEFINITION

THE TEST MODE mode enables the users to override the programming of the DL-5002HC. Each channel can be enabled or disabled, to manually open and or close a solenoid valve or to put into a continuous lube cycle for routine preventive maintenance requirements. See **13.0** for detailed operation

11.12 “FORCE LUBE CYCLE” DEFINITION

The FORCE LUBE CYCLE zero’s the OFF COUNTS. This will force a lube cycle on the next sensor detection. After the lube cycle has been completed, the channel will automatically return to it’s programmed OFF COUNTS. See 14.0 for detailed operation

11.13 PIN SECURITY CODE

In order to program the DL-5002HC, it is necessary to know the four-digit PIN security code. This will enable the user to restrict the number of people authorized to maintain the equipment and to change program settings. The code is preset at the factory at 0000. See 15.0 on Configure mode for instructions on setting a different security code.

12.0 PROGRAMMING LINK MODE

Programming the DL-5002HC is very easy if a few things are kept in mind.

- Press “A” once for Program Mode
- Press “A” twice for Test Mode
- Press “B” to Force Lube Cycle
- Press “C” for Configure Mode

12.1 While programming a channel, remember the following:

- Press “A” to advance screens
- Press “D” anytime to return to Main Screen
- Follow the Screen Prompts
- When changing values, press * button to save the new values

12.2 MAIN COUNT SCREEN	CH1	CH2	CH3	CH4
OFF COUNTS	0000	0000	0000	0000
NUMBER OF LINKS	0000	0000	0000	0000
FEET PER MINUTE	0000	0000	0000	0000
OZ/LUBE CYCLE	0000	0000	0000	0000

12.3 STEP BY STEP PROGRAMMING LINK MODE

The following example will take you step by step on programming a channel to lubricant chain pins on a monorail I-Beam conveyor. You have a “RapidFlex or Jervis B Webb type” enclosed track conveyor with 8” chain links and it is a 600’L. You want to lubricate the vertical wheels (channel 1) every fifth cycle, and you want to dispense a small amount of lubricant. The valve has two .031 I.D. dispensing tubes and you have determined the pressure at the solenoid valve is 30 PSI.

12.4 CHANNEL ASSIGNMENT(S)

Enclosed Track Lubricator

CH1 – Vertical Trolleys CH2 – Pivot Points & Guide Rollers
CH3 - Cat drive chain/swivel CH4 - Free carrier

12.5 FROM THE MAIN COUNT SCREEN

- Press “A” once
- Press “*” to enter Program Mode
- Enter PINsecurity code (preset 0000 at factory)
- Press “*” to continue
- Select channel

- Press “A” to continue
- Operation mode choose **LINK MODE** use “*” to select
- Press “A” to continue
- Enter OFF COUNTS 0005 (**PRESS * TO SAVE**)
- Press “A” to continue
- Enter # OF LINKS 0900 (**PRESS * TO SAVE**)
- Press “A” to continue
- Enter LUBE TIME 0001 (**PRESS * TO SAVE**)
- Press “A” to continue
- Enter DEBOUNCE TIME 0250 (**PRESS * TO SAVE**)
- Press “A” to continue
- Enter FEET PER MINUTE 080.0 (**PRESS * TO SAVE**)
- Press “A” to continue

12.6 You have just completed programming Channel 1, press “A” and program the remaining channel (s) or press “D” to return to the Main Count Screen.

13.0 HOW TO OPERATE TEST MODE

The TEST MODE allows the user to enable/disable any channel, open/close any valve or begin a continuous lube cycle.

13.1 EXAMPLE 1: Screen One - Enable/Disable a channel. This feature is used primarily during installation and routine maintenance checks. When adjusting the dispensing tubes for the first time, it allows the installer, to remove air from the supply line(s) and/or to adjust the dispensing tubes, one valve at a time. This reduces an accumulation of lubricant on the rail, floor, parts, etc from misdirected dispensing tubes.

- From the Main Count Screen, Press “A” twice to enter Test mode and enter PIN #
- Press “*” once to advance screen Enter appropriate channel.
- Press * to Enable channel
- Press “D” to return to Main Count Screen

13.2 EXAMPLE 2: Screen two - Open/Close a Valve. This feature is used mainly during installation/startup to bleed air out of the nylon supply tubing, or whenever air is trapped in the tubing.

- From the Main Count Screen, Press “A” twice to enter Test mode
- Enter appropriate channel
- Press “A” twice to advance the screen to Open/Close
- Press * to Open Valve,
- Press * again to Close Valve
- Press “D” to return to Main Count Screen

13.3 EXAMPLE 3: Screen three - Continuous Lube. This feature will immediately put the channel into a continuous lube cycle. Use this mode if the conveyor chain is extremely dry, and you want to lube it several cycles or if the conveyor requires continuous lubrication.

- From the Main Count Screen, Press “A” twice to enter Test mode

- Enter appropriate channel
- Press “A” three times to advance the screen to Continuous Lube
- Press “*” to read YES. The selected channel will now lubricate continuously
Press “D” to return to Main Count Screen

14.0 HOW TO OPERATE THE FORCE LUBE CYCLE

The FORCE LUBE CYCLE allows the user to begin a lube cycle immediately. This is usually done if the chain looks usually dry and you want to lube it but keep the existing program.

- Press “B” to advance screen to Force Lube Cycle
- Press * to Force Lube Cycle
- Enter appropriate channel and Press * to start

15.0 HOW TO OPERATE CONFIGURE MODE

The CONFIGURE MODE allows user to change PIN security codes, Real Time Clock (in the Time Mode only) and choose different Baud Rates for the optional ASCII Communication.

15.1 TO CHANGE PIN SECURITY CODE

- Press “C” to enter Configure Mode
- Press * to enter
- Enter present PIN security code _ _ _ _
- Press * to continue
- Press * to enter new PIN security code
- Enter new PIN security code _ _ _ _
- Press * to save.
- Press “D” to return to Main Count Screen or “A” to continue and set Real Time Clock

HR	MIN	SEC	MO	DA	YR
00	00	00	00	00	00

NOTE: Cursor will shift from the most significant digit to the next and back again.

There is no need to press * to save.

- Press “D” to return to Main Count Screen or “A” to continue and set Baud Rate
- Press * to change baud rate(1200,2400,4800,9600)
- Press “D” to return to Main Count Screen or “A” to continue

16.0 PROGRAMMING TIME MODE

The TIME MODE is used to lubricate, sprockets, and/or high speed chains where a sensor(s) cannot be used and on a wide variety of machines.

MAIN COUNT SCREEN	CH1	CH2	CH3	CH4
00 DAYS 00 HOURS	0000	0000	0000	0000
00 MIN. 00 SEC	0000	0000	0000	0000
FEET PER MINUTE	0000	0000	0000	0000
OZ/LUBE CYCLE	0000	0000	0000	0000

16.1 In the TIME MODE the user programs the channel for CYCLE TIME which indicates the time between lubrication cycles, ON COUNTS which indicates the number of shot of lubricant, LUBE TIME which determines how long the valve remains open, DURATION BETWEEN which indicates the length of time between each shot of lubricant.

16.2 STEP BY STEP PROGRAMMING TIME MODE FROM MAIN COUNT SCREEN

- Press “A” once for Program Mode
- Press “*” to enter
- Enter PIN security code (preset 0000 at factory)
- Press “*” to continue
- Select channel 1 - 4
- Press “A” to continue
- Operation mode, Press “*” to toggle to TIME MODE
- Press “A” to continue

• Enter CYCLE TIME days hours min. sec.
 00 00 00 00

(Cursor will shift from the most significant digit to the next and back again. There. is no need to press * to save.)

- Press “A” to continue
- Enter # of ON COUNTS in the cycle - 0500 **(PRESS * TO SAVE)**
- Press “A” to continue
- Enter LUBE TIME 0001 **(PRESS * TO SAVE)**
- Press “A” to continue
- Enter DURATION BETWEEN 0993 **(PRESS * TO SAVE)**
- Enter FEET PER MINUTE 003.0 **(PRESS * TO SAVE)**
- Press “A” to continue
- Enter OZ/LUBE CYCLE 0000 See Lube Chart at ??. **(PRESS * TO SAVE)**

16.3 One channel has been programmed in the TIME MODE. Select another channel or Press “D” to return to MAIN COUNT SCREEN

16.4 ACTUAL SCREEN READOUTS

LUBE PROGRAM FUNCTIONS REV 3.1 DL-5002 HC

SCREEN DISPLAYS

MAIN SCREEN ON POWER UP

By pressing "D" anytime returns you to
MAIN SCREEN

PRESS "A"

"Program Mode"

PRESS "*" to enter Program Mode
PRESS "A" to enter Test Mode

PRESS "*" and screen will read

enter correct pin number now
(Pre-set to "0000" from manufacturer)

If you enter **incorrect** pin number
screen will read

PRESS "A"
and screen returns to MAIN SCREEN
you must start again

PRESS "A"

PRESS "*" to enter Program Mode
PRESS "A" to enter Test Mode

```

                                L C D
4  L I N E   2 0   C H A R A C T E R
      A C T U A L   F O R M A T
- - - - -
0 0 0 5   0 0 0 5   0 0 0 5   0 0 0 5
0 0 0 5   0 0 0 5   0 0 0 5   0 0 0 5
0 0 . 0   0 0 . 0   0 0 . 0   0 0 . 0
0 0 . 0   0 0 . 0   0 0 . 0   0 0 . 0
- - - - -
p r e s s   *   t o   e n t e r
          P R O G R A M   M O D E
p r e s s   A   t o   e n t e r
          T E S T   M O D E
- - - - -
p l e a s e   e n t e r   p i n   #
- - - - -
                                D L - 5 0 0 2   H C
- - - - -
i n c o r r e c t   p i n   n u m b e r
p r e s s   A   t o   e s c a p e
                                D L - 5 0 0 2   H C
- - - - -
0 0 0 5   0 0 0 5   0 0 0 5   0 0 0 5
0 0 0 5   0 0 0 5   0 0 0 5   0 0 0 5
0 0 . 0   0 0 . 0   0 0 . 0   0 0 . 0
0 0 . 0   0 0 . 0   0 0 . 0   0 0 . 0
- - - - -
p r e s s   *   t o   e n t e r
          P R O G R A M   M O D E
p r e s s   A   t o   e n t e r
          T E S T   M O D E
- - - - -

```

LUBE PROGRAM FUNCTIONS REV 3.1 DL-5002 HC

“Program Mode” cont.

p l e a s e e n t e r p i n #

enter correct pin number now
(Preset to “0000” from manufacturer)
“xxxx”
as you are entering correct pin number
screen will read “xxxx”

D L - 5 0 0 2 H C

c o r r e c t p i n n u m b e r
p r e s s * t o c o n t i n u e

PRESS “*” and screen will read

D L - 5 0 0 2 H C

you must select the channel to program
now

s e l e c t c h a n n e l t o
p r o g r a m (1 t o 4 1
p r e s s A t o c o n t i n u e

PRESS “A”

D L - 5 0 0 2 H C

Here is where you can choose Link or
Time Mode. We will go into **Link** Mode
now. For Time Mode see pages 4,5

c h 1 o p e r a t i o n m o d e
* t o t o g g l e , l i n k m d e

Link Program Mode

PRESS “A”

p r e s s A t o c o n t i n u e

Enter the number of off cycles (complete
revolutions of conveyor without
lubricating) **PRESS “*”** to save

c h 1 # o f o f f c y c l e s
p r e s s * t o s a v e 0 0 0 0

PRESS “A”

p r e s s A t o c o n t i n u e

Enter the number of links (the number of
targets your sensor will pick-up)
PRESS “*” to save

c h 1 # o f l i n k s
p r e s s * t o s a v e 0 0 0 0

PRESS “A”

p r e s s A t o c o n t i n u e

Enter lube time. A setting of 0001 is the
minimum setting. A setting of 0001 - 0003
is normal for enclosed type conveyors
PRESS “*” to save

c h 1 l u b e t i m e (m s e c)
p r e s s * t o s a v e 0 0 0 0

PRESS “A”

p r e s s A t o c o n t i n u e

LUBE PROGRAM FUNCTIONS REV 3.1 DL-5002 HC

“Link Program Mode” cont.

Enter switch debounce time now. This keeps a shaking conveyor from inputting twice on the same input. **PRESS “*”** to save

“PRESS A”

To have feet per minute calculated you must enter the number of inches per links here, ~~xxxx~~ **PRESS “*”** to save (six and one half inch link **press ” 0065”**) **PRESS “A”**

This is used for machine lubrication only at this time. Preset to **0000** from factory **PRESS “*”** to save **PRESS “A”**

By pressing “A” you return to first programming screen. You must now choose another channel or you will scroll thru previous channel’s screens.

PRESS “D” to escape.
This returns you to **MAIN SCREEN**

Always follow screen instructions.

```

c h l   d e b o u n c e       ( m s e c )
p r e s *   t o   s a v e   0 0 0 0

p r e s s   A   t o   c o n t i n u e
- - - - -

c h l   c o n v e y o r   s p e e d
p r e s *   t o   s a v e   0 0 0 0
#   o f   i n c h s   p e r   l i n k
p r e s s   A   t o   c o n t i n u e
- - - - -

c h l   l u b e   r a t e
p r e s *   t o   s a v e   0 0 0 0
g r a m s / 1 0 s e c   f l o w   r t
p r e s s   A   t o   c o n t i n u e
- - - - -

s e l e c t   c h a n n e l   t o
p r o g r a m   ( 1 t o 4 )   1
p r e s s   A   t o   c o n t i n u e

D L - 5 0 0 2   H C
- - - - -
0 0 0 5   0 0 0 5   0 0 0 5   0 0 0 5
0 0 0 5   0 0 0 5   0 0 0 5   0 0 0 5
0 0 . 0   0 0 . 0   0 0 . 0   0 0 . 0
0 . 0 0   0 . 0 0   0 . 0 0   0 . 0 0
- - - - -

```

LUBE PROGRAM FUNCTIONS REV 3.1 DL-5002 HC

“Time Program Mode”

The Time Program Mode is an elapse timer
 in this example we will lubricate every
 8hrs and 30 minutes

PRESS “A” then **PRESS “*”** and
 enter correct pin number now
 (Preset to “0000” from manufacturer)
 “xxxx”
 as you are entering correct pin number
 screen will read “xxxx”

```

- - - - -
      p l e a s e       e n t e r   p i n   #
- - - - -
                D L - 5 0 0 2       H C
- - - - -
      c o r r e c t   p i n   n u m b e r
      p r e s s   *   t o   c o n t i n u e
  
```

PRESS “*” and screen will read
 you must select the channel to program
 now

```

                D L - 5 0 0 2       H C
- - - - -
      s e l e c t   c h a n n e l   t o
      p r o g r a m   ( 1   t o   4   1
      p r e s s   A   t o   c o n t i n u e
                D L - 5 0 0 2       H C
  
```

PRESS “A”
 Choose **Link** or **Time** Mode. To enter
Time Mode. **PRESS “*”** to toggle from
 Link Mode.

```

- - - - -
      c h 1   o p e r a t i o n   m o d e
                l i n k   m o d e
                *   t o   d i s a b l e
      p r e s s   A   t o   c o n t i n u e
  
```

PRESS “*” and screen will read

```

- - - - -
      c h 1   o p e r a t i o n   m o d e
      *   f o r   l i n k   ,   D I S A B L E D
      #   *   f o r   t i m e   m o d e
      p r e s s   A   t o   c o n t i n u e
  
```

PRESS “#” and screen will read

```

- - - - -
      c h 1   o p e r a t i o n   m o d e
                t i m e   m o d e
                #   *   t o   d i s a b l e
      p r e s s   A   t o   c o n t i n u e
- - - - -
  
```

PRESS “A”

LUBE PROGRAM FUNCTIONS REV 3.1 DL-5002 HC

“Time Program Mode” cont.

Enter your Time Base now, example 0 0 : 0 8 : 3 0 : 0 0
 00days: 08 hours: 30 minutes: 00 seconds:
 99 days:23 hours:59 minutes:59 seconds:
 Is the maximum interval between lube cycles

enter cycle time
 press A to continue

 ch1 # of on counts

Enter the number of on counts (the number of points you want to lubricate)
 press * to save 0 0 0 0

press A to continue

press A

 ch1 lube time (msec)

Enter lube time setting of 0001 equals 7 msec. A setting of 0001 is the minimum setting
 press * to save 0 0 0 1

press A to continue

press A

 ch1 duration between

Duration between has to be a longer time than the lube time or else the output will not have time to shut off. This example will apply a small amount of lube every 1/2 second (0500)
 press * to save 0 5 0 1

press A to continue

press A

 ch1 conveyor speed

In the time mode you cannot calculate feet per minute because you don't use a sensor. Just skip over this screen and
 press * to save 0 0 0 0

of inches per link
 press A to continue

press A

 ch1 lube rate

Choose your situation (Number of tubes, size of tube, pressure of tank) from Digilube's chart 28.5 grams press "0285"
 press * to save 0 2 5 0

grams / 10 sec flow rt
 press A to continue

press A

By pressing "A" you return to first programming screen. You must now choose another channel or you will scroll thru previous channel's screens.

0 0 0 8 0 0 0 5 0 0 0 5 0 0 0 5
 3 0 0 0 0 0 0 5 0 0 0 5 0 0 0 5
 0 0 . 0 0 0 . 0 0 0 . 0 0 0 . 0

press "D" to return to
 0 . 0 0 0 . 0 0 0 . 0 . 0 0 0 . 0 0 0

MAIN SCREEN

LUBE PROGRAM FUNCTIONS REV 3.1 DL-5002 HC

"A" BUTTON cont. Test Mode	0 0 0 5	0 0 0 5	0 0 0 5	0 0 0 5
<u>MAIN SCREEN ON POWER UP</u>	0 0 0 5	0 0 0 5	0 0 0 5	0 0 0 5
In test mode you can select different channels at any time.	0 0 . 0	0 0 . 0	0 0 . 0	0 0 . 0
	0 . 0 0	0 . 0 0	0 . 0 0	0 . 0 0
PRESS "A"	- - - - -	- - - - -	- - - - -	- - - - -
PRESS "*" to enter Program Mode	p r e s s	*	t o	e n t e r
PRESS "A" to enter Test Mode.	P R O G R A M	M O D E		
	p r e s s	A	t o	e n t e r
PRESS "A"	T E S T	M O D E		
	- - - - -	- - - - -	- - - - -	- - - - -
ENTER CORRECT PIN NUMBER	p l e a s e	e n t e r	p i n	#
an incorrect PIN number will force you to start over.				- - - -
PRESS "xxxx"				
	D L -	5 0 0 2	H C	
	- - - - -	- - - - -	- - - - -	- - - - -
PRESS "*" to continue in Test Mode	c o r r e c t	p i n	n u m b e r	
	p r e s s	*	t o	c o n t i n u e
	D L -	5 0 0 2	H C	
	- - - - -	- - - - -	- - - - -	- - - - -
To enable or disable any channel (choose chn. now) PRESS "*" this allows you to perform any necessary work on an individual channel during set-up.	c h 1	E n a b l e		
	*	t o	t o g g l e	
PRESS "A"				
	p r e s s	A	t o	c o n t i n u e
Open/Close any channel (choose chn. now) PRESS "*" This is helpful when you initially setup. When you leave Test Mode this function defaults to Closed.	- - - - -	- - - - -	- - - - -	- - - - -
	c h 1	V a l v e	c l o s e d	
PRESS "A"				
	p r e s s	*	t o	t o g g l e
	p r e s s	A	t o	c o n t i n u e
	- - - - -	- - - - -	- - - - -	- - - - -
Lube any channel (choose chn. now) PRESS "*" For every sensor input you get an output. PRESS "A" to continue in Test Mode	c h 1	c o n t i n u o u s	l u b e	
PRESS "D" to escape and return to <u>MAIN SCREEN</u>	*	t o	t o g g l e	N O
	p r e s s	A	t o	c o n t i n u e
	- - - - -	- - - - -	- - - - -	- - - - -

LUBE PROGRAM FUNCTIONS REV 3.1 DL-5002 HC

"B" BUTTON Force Lube Mode
MAIN SCREEN
ON POWER UP

```
0 0 0 5    0 0 0 5    0 0 0 5    0 0 0 5
0 0 0 5    0 0 0 5    0 0 0 5    0 0 0 5
0 0 . 0    0 0 . 0    0 0 . 0    0 0 . 0
0 . 0 0    0 . 0 0    0 . 0 0    0 . 0 0
```

PRESS "B"
screen will read

```
- - - - -
p r e s s      *   t o   f o r c e
a l u b e c y c l e
```

```
DL - 5 0 0 2   H C
```

PRESS "*"
screen will read

```
- - - - -
s e l e c t   c h   *   t o   f r c
c h 1      ( *   t o   s t a r t )
```

Force any channel (choose chn. now)
PRESS "*" to force a lube cycle

When you force a lube cycle the off/on counts go to 1/1; next input zeros the off counts and the on count goes to the programmed amount. This is very useful when you have a conveyor that needs lubrication. Once the force lube has completed the program returns to the original programmed settings. If power is removed, the processor remembers and will return to force lube when power is applied.

LUBE PROGRAM FUNCTIONS REV 3.1 DL-5002 HC

<u>"C" BUTTON Configure Mode</u>	0 0 0 5	0 0 0 5	0 0 0 5	0 0 0 5
<u>MAIN SCREEN ON POWER UP</u>	0 0 0 5	0 0 0 5	0 0 0 5	0 0 0 5
In configure mode you can set the real-time clock, choose your own personal identification number or change the network communication rates. Defaults equal pin # 0000 and 1200 bps	0 0 . 0	0 0 . 0	0 0 . 0	0 0 . 0
	0 . 0 0	0 . 0 0	0 . 0 0	0 . 0 0
	- - - -	- - - -	- - - -	- - - -
	p r e s s	* t o	e n t e r	
PRESS "C" screen will read	c o n f i g u r e	m o d e		
PRESS "**"		D L - 5 0 0 2	H C	
When DL-5002 HC is first Powered Up the pin number is 0000. Enter 0000 and follow screen instructions.	- - - -	- - - -	- - - -	- - - -
	p l e a s e	e n t e r	p i n #	
	- - - -			
PRESS "0000"		D L - 5 0 0 2	H C	
	- - - -	- - - -	- - - -	- - - -
	c o r r e c t	p i n	n u m b e r	
PRESS "**" to continue	p r e s s	* t o	c o n t i n u e	
		D L - 5 0 0 2	H C	
	- - - -	- - - -	- - - -	- - - -
PRESS "**" for New Pin number	p r e s s	* t o	b e g i n	
	e n t r y	o f	n e w	p i n
PRESS "**" screen will read	p r e s s	A	t o	c o n t i n u e
choose new pin number now	- - - -	- - - -	- - - -	- - - -
PRESS "*" to save	n e w	p i n	n u m b e r	
PRESS "A" to continue	p r e s s	* t o	s a v e	0 0 0 0
This is where the real-time clock is set it is in Military Time Eastern Standard Time 09:27:29 =9:27 and 29 sec.AM on June. 20, 2001 The # key will move the cursor right and the 9 key will move it left.	p r e s s	A	t o	c o n t i n u e
	- - - -	- - - -	- - - -	- - - -
	0 9 :	2 7 :	2 9	0 9 - 3 0 - 9 5
	3 =	u p	6 =	d o w n
	9 =	l e f t	# =	r i g h t
PRESS "A" to continue	p r e s s	A	t o	c o n t i n u e
	- - - -	- - - -	- - - -	- - - -

LUBE PROGRAM FUNCTIONS REV 3.1 DL-5002 HC

“C” BUTTON configure mode cont.
 You can now change the network communication rates. Defaults 1200bps

PRESS “*” to change baud rate
 once for 2400
 twice for 4800
 three times for 9600
 four times back to 1200

```

- - - - -
b a u d   r a t e   =   1 2 0 0
p r e s s   *   t o   c h a n g e
    
```

If you **PRESS “A”** you go back to pin number entry.

```

p r e s s   A   t o   c o n t i n u e
- - - - -
    
```

PRESS “D” to escape configure mode and return to **MAIN SCREEN**

```

0 0 0 5   0 0 0 5   0 0 0 5   0 0 0 5
0 0 0 5   0 0 0 5   0 0 0 5   0 0 0 5
0 0 . 0   0 0 . 0   0 0 . 0   0 0 . 0
0 . 0 0   0 . 0 0   0 . 0 0   0 . 0 0
- - - - -
    
```

17.0 MAINTAINING THE LUBRICATION SYSTEM

The Digilube Lubrication System with the DL-5002HC is the most advanced lubricator on the market today. It will provide many years of trouble free lubrication. However, **regular maintenance is a must** to insure the equipment is operating properly, dispensing tubes properly adjusted and that the conveyor is getting the correct amount of lubricant. The plant maintenance personnel should inspect the system at least monthly if not weekly. The following maintenance steps should be adhered to closely:

17.1 Check lubricator to make sure dispensing tubes are properly adjusted. Make sure all dispensing tube outlets for each valve are at the same level to prevent dripping from lower tubes.

17.2 Inspect the sensor(s) LED for proper activation and make sure the sensor is tightly secured onto the bracket.

17.3 Inspect conveyor chain, trolleys, etc for sufficient amount of lubricant

17.4 Check and maintain a sufficient amount of lubricant in the tank to prevent automatic shutdown caused by an empty tank.

17.5 If the maintenance department does not have the personnel to devote to maintaining the equipment, a Maintenance Service Contract by Digilube Systems or an authorized representative is recommended.

18.0

DL-121 Enclosed Track Lubricator

MODEL
<input type="checkbox"/> DL-111
<input type="checkbox"/> DL-121
<input type="checkbox"/> DL-122
<input type="checkbox"/> DL-123
<input type="checkbox"/> OTHER

ITEM#	QUANTITY	PART#	DESCRIPTION
1	1	E06300	MICROPROCESSOR -DL-5001HC
2A	3	E05850	LAMP - 28VDC
2B	1	E05900	LAMP COVER - AMBER
2C	1	E05950	LAMP COVER - CLEAR/GREEN
2D	1	E06000	LAMP COVER - YELLOW
3	1	H14700	BRACKET, UPRIGHT
4A	5	H14850	HOLD DOWNS, SMALL
4B	5	H14900	HOLD DOWNS, LARGE
5A	1	F09355	DISPENSING TUBE 2T.031(DRY FILM)
5B	3	F09360	DISPENSING TUBE 3T.031
5C	1	F09655	DISPENSING TUBE 2T.060(SYN.FILM)
5D	3	F09660	DISPENSING TUBE 3T.060
6	2	H14600	BRACKET, "S"
7	2	F07250	SENSOR, INDUCTIVE
8	2	F12000	MALE CONNECTOR 1/8"-1/8"
9A	2	F12950	VALVE, SOLENOID 115VAC
9B	2	F12955	VALVE, SOLENOID 24VDC
10	1	F11950	MALE ELBOW SWIVEL 1/4"-1/8" 90D
11	1	H14100	BASE PLATE-MANIFOLD
12A	1	I16400	UNIBILT, REG. TRACK MODIFIED
12B	1	I16650	RICHARD WILCOX REG. TRACK MOD.

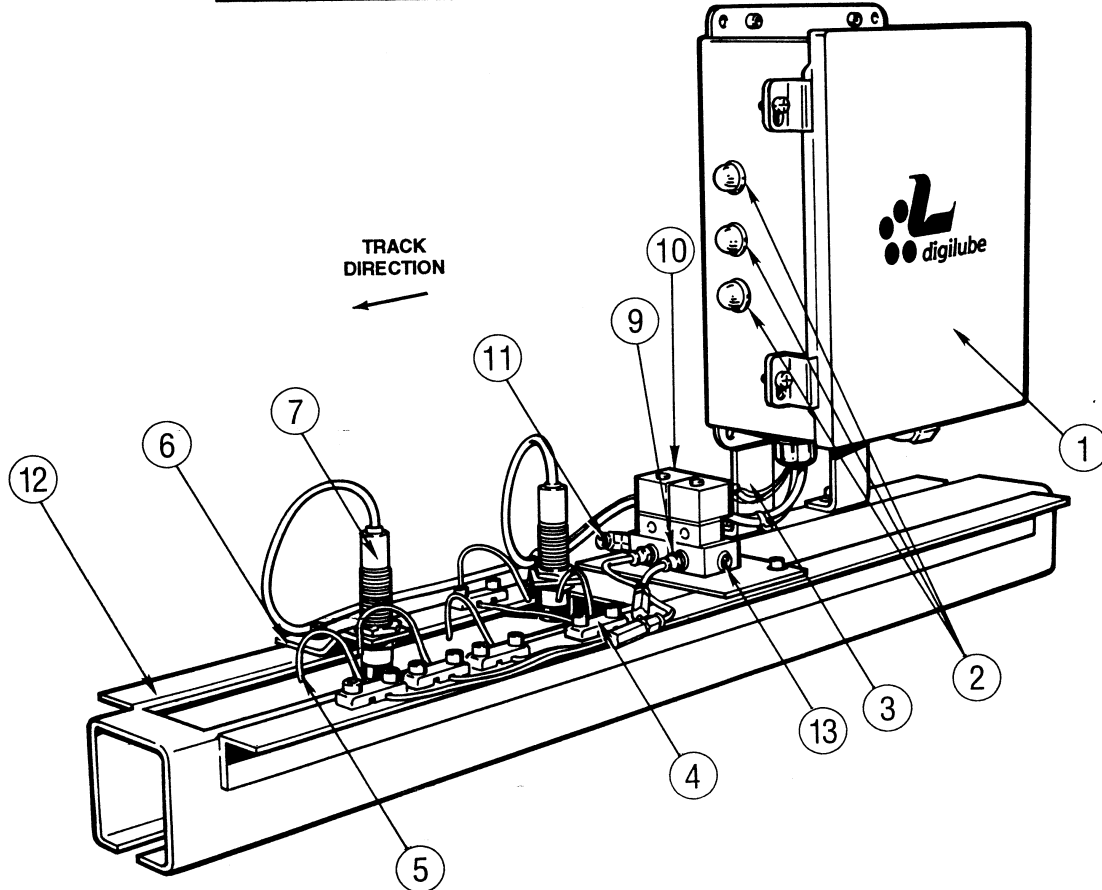

18.3 DL-806 LUBRICANT TANK

ITEM #	QUANTITY	PART #	DESCRIPTION
1	1	E06400	Motor, 1/3 HP
2	1	F11650	Male Connector 1/4" x 1/4"
3	1	F10900	Gauge, Pressure
4	1	F09300	Check Valve, 3/8"
5	1	F09200	Cap Filler Breather Assy.
6	1	F12600	Strainer Brass 1/4"
7	1	E07400	Switch, Level Control
8	1	F12500	Pump, Gear
9	16"	F11100	Hose, Fuel Line 1/4" I.D.
10	1	F13300	Valve, Pressure Relief

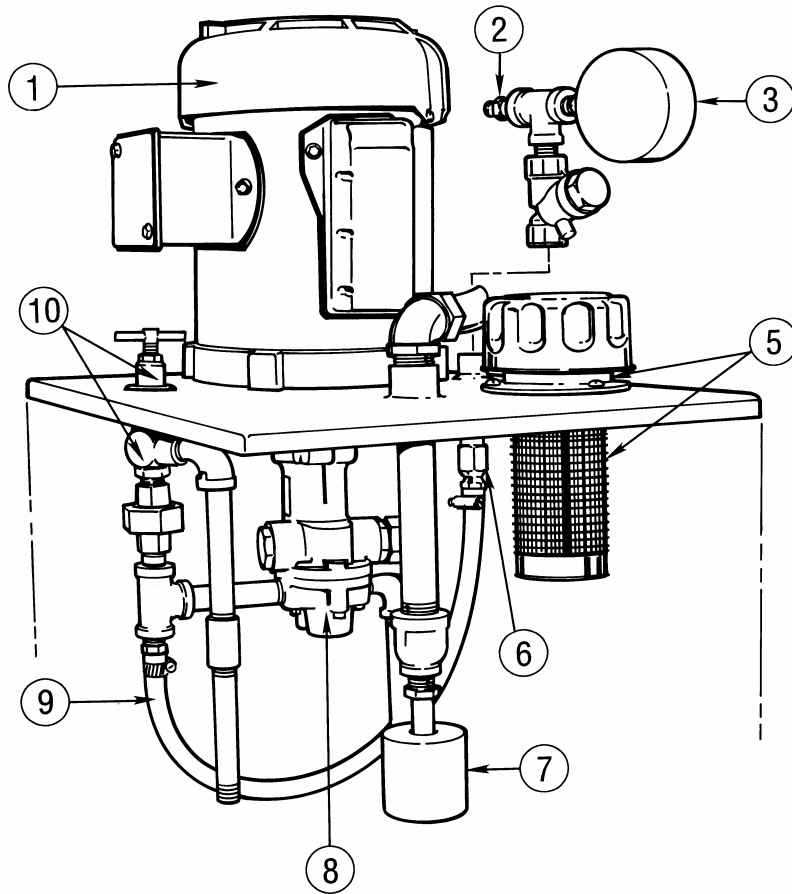

18.1 DL-5002 CONTROLLER

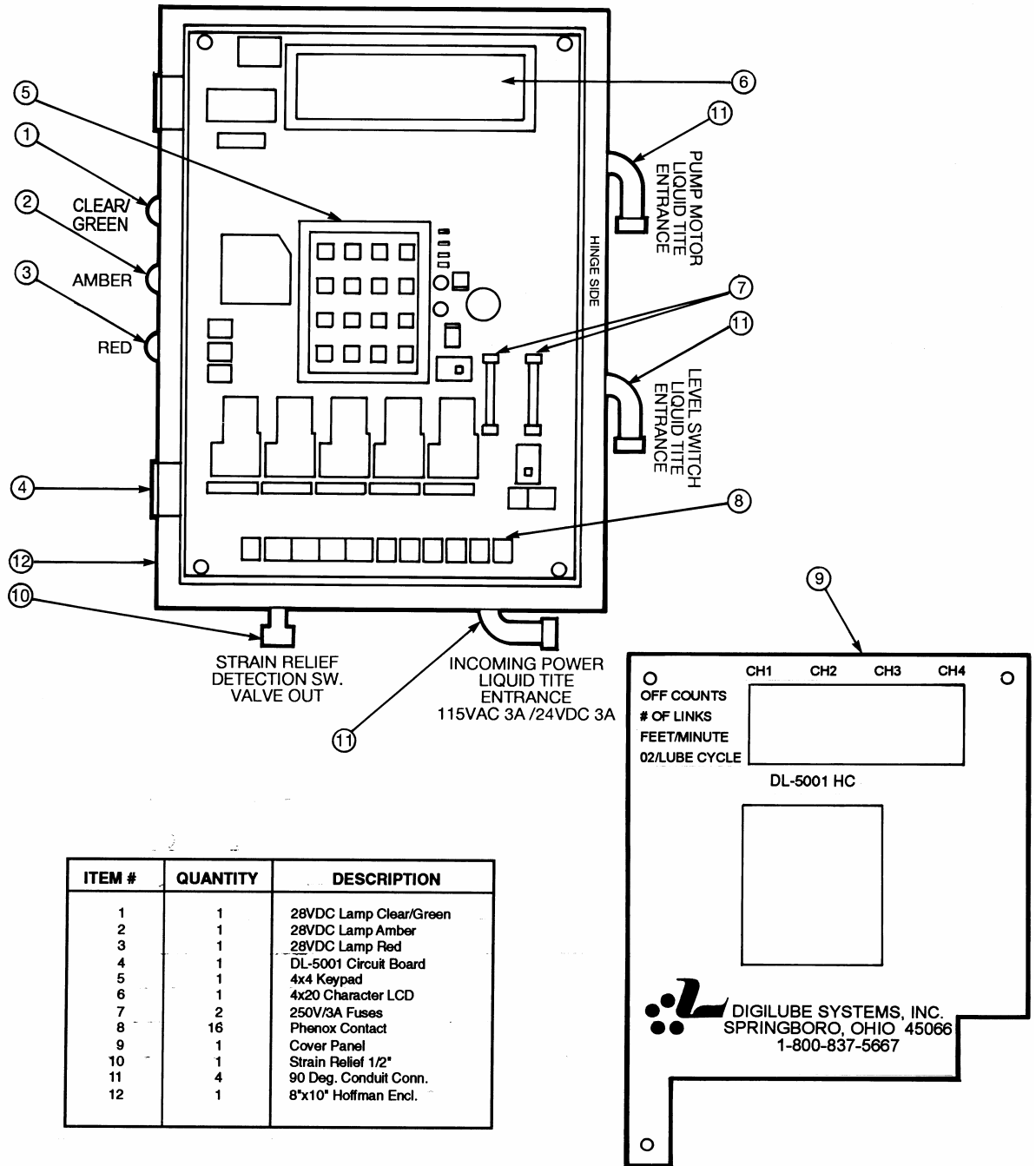

ITEM #	QUANTITY	DESCRIPTION
1	1	28VDC Lamp Clear/Green
2	1	28VDC Lamp Amber
3	1	28VDC Lamp Red
4	1	DL-5001 Circuit Board
5	1	4x4 Keypad
6	1	4x20 Character LCD
7	2	250V/3A Fuses
8	16	Phenox Contact
9	1	Cover Panel
10	1	Strain Relief 1/2"
11	4	90 Deg. Conduit Conn.
12	1	8"x10" Hoffman Encl.

18.2 DL-5002 WIRING DIAGRAM

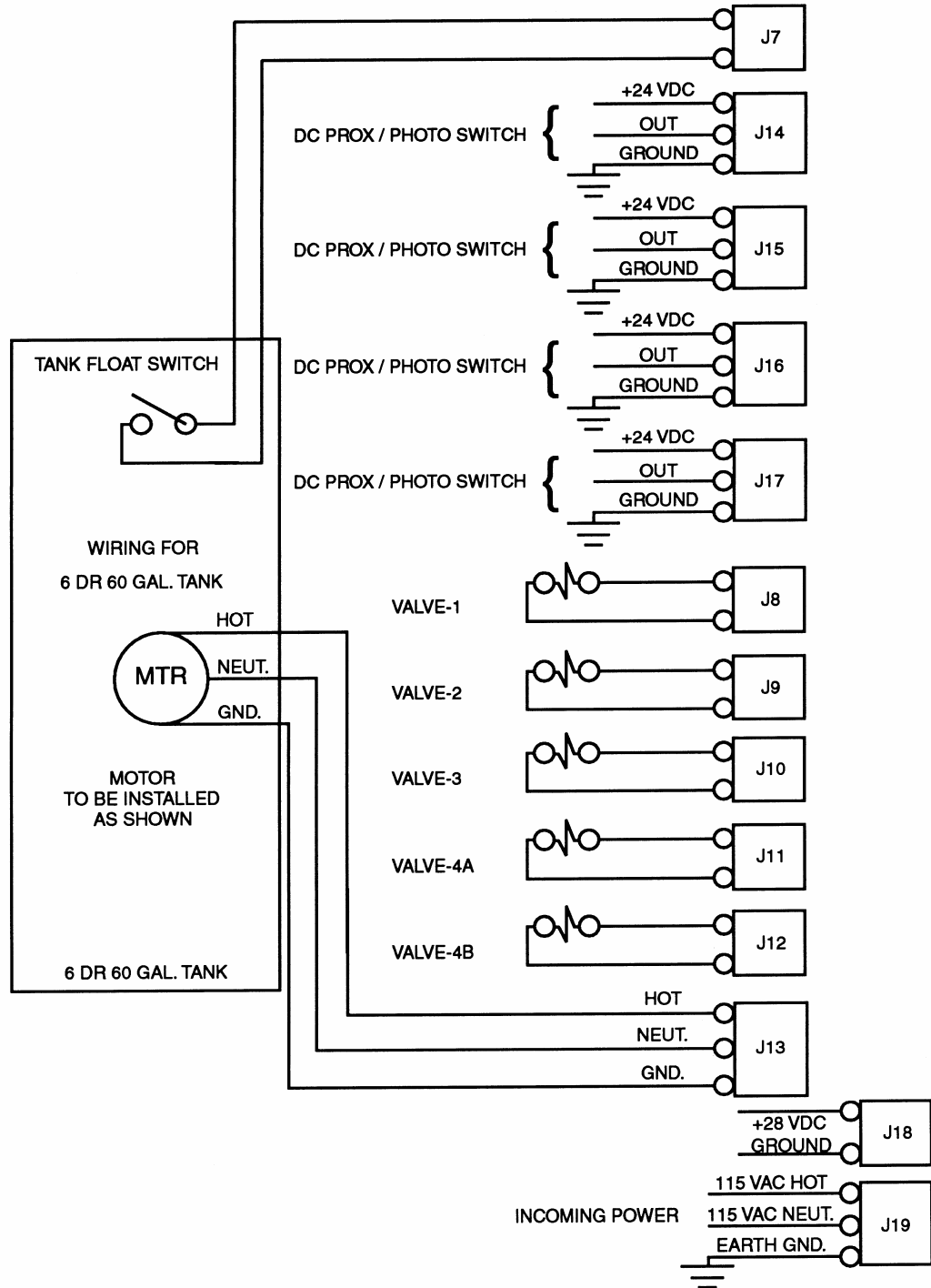

21.0 SUGGESTED SPARE PARTS

Although Digilube Systems provides rapid response and shipping of replacement parts, we offer the following spare parts listing for the user to stock as desired:

21.1 DL-5001 HC LUBRICATOR

F13150	Valve, Solenoid 24 VDC
E07250	Sensor Inductive 24 VDC
E07101	Sensor Photo-Electric 24 VDC
F09455	Dispensing Tubes 2T-.042
F09460	Dispensing Tubes 3T-.042 (only with cat drive lubricator)
E05850	Lamps LED Indicator-28 VDC
E06301	DL-5002HC replacement board*

21.2 LUBRICANT TANK

E05855	Lamp LED Indicator for DL9000PS 115 VAC
F12557	Pump - Gear*
E06550	DL-9000PS/115 VAC Output*
E06600	DL-9000PS/24 VDC Output*

* Should be considered for major type systems

21.3 If five or more Lubricators are being used in critical applications, such as oven conveyors, then stocking the major spare parts should be considered.

22.0

LIMITED WARRANTY

The Digilube Lubrication System is pretested and guaranteed to be in optimum condition when it leaves our factory. The DL-5002HC is fully guaranteed against defective materials and/or workmanship for a period of thirty-six (36) months from the date of purchase. Any portion of the DL-5002HC which fails during this period for either of the above reasons, excluding normal replacement parts such as indicator lamps, fuses, etc., , will be repaired or replaced at our option, if returned prepaid to our factory. All defective parts returned for warranty service is fully inspected to determine cause of failure before warranty is approved. All other equipment components are guaranteed against defective materials or workmanship for a period of twelve months from the date of purchase. Our warranty is limited to the obligation to repair or replace our equipment only.

22.1 This warranty gives you specific legal rights and you may have other rights which vary from state to state.

22.2 The Digilube warranty will be void if any of the following conditions are found to exist relative to Digilube's equipment.

22.3 Electronics components tampered with, or short circuited

22.4 Damaged caused from voltage or environmental conditions exceeding the operating conditions.

22.5 Failure due to using lubricants that do not fall with the specified viscosity range. All non Digilube lubricants must be approved, in advance by Digilube Systems Inc. to maintain warranty coverage.

DIGILUBE PROGRAMMABLE LUBRICATION SYSTEM INSTALLATION / OPERATIONAL MANUAL

1.0 INTRODUCTION The Digilube Programmable Lubrication System is designed for lubricating a wide variety of conveyors and machines. The DL-5003 Head Controller (HC) which controls the lubricator is the most technologically advanced, yet easy to use microprocessor in the industry. A large four line LCD screen and 16 button key pad provide on-screen instructions for programming the unit and adjusting the lubricator for your particular conveyor. This manual provides complete information needed to install, program, service and order replacement components for your system.

2.0 DESCRIPTION

2.1. The DL series of Digilube's programmable lubricators provide pinpoint accuracy of lubricant to many different types of conveyors' lube points. Typical areas of lubrication include chain pins, open trolley bearings, free carriers, swivels, cat drive chains, roller chain, etc.

2.2 Each system consists of a lubricator with a DL-5003HC and a lubricant tank. The DL-5003HC is a Programmable Microprocessor Head Controller that controls the system. It has four (4) independent channels, 115 VAC or 24 VDC outputs, four digit PIN security code, easy-to-read LCD screen, 16-button key pad...and much more.

3.0 SPECIFICATIONS

3.1 LUBRICATOR WITH DL-5003HC

Dimensions/Weight

- Lubricator will vary depending on type of conveyor and/or if pre-mounted.

DL-5003HC (Head Controller)

- 15 lbs - 8" x 10"

Circuitry

- Solid state electronics, microprocessor controlled

Power Requirements

- 115 VAC 3 Amps or 24 VDC 3 Amps

Operating Temperatures

- 45° F minimum- 120° F maximum

Relative Humidity

- 5 – 90% Non Condensing

Authorization Security Code

- Four (4) digit, preset at factory to 0000

Memory

- EPROM

Lube Time (Volume Control)

- Adjustable settings from 0001 to 9999

Paint/Color

- Powder/Gray with Burgundy Logo

3.2 LUBRICANT TANKS

The lubricator can be connected to several different size lubricant tanks:

- DL-806 - 6 gal 18 1/2"H x 12 1/2"W x 15"L WT 60#. Can be mounted on the conveyor track in back of the lubricator or positioned waist high on a column for easy filling
- DL-812 - 12 gal 22 1/2"H x 12 1/2"W x 15"L WT 75#. Comes with or without DL9000 power Supply and is positioned waist high on column for easy filling..
- DL-865 - 65 gal, 49"H x 22 1/2"W x 22 1/2"L WT 210#. Comes with or without a DL9000 power supply. This tank is designed to provide lubricant from a single source to multiple lubricators. The DL9000 power supply comes in either 115 VAC or 24 VDC output.

DIGILUBE PROGRAMMABLE LUBRICATION SYSTEM INSTALLATION / OPERATIONAL MANUAL

DL-9000PS/115 (Power Supply)	• 15 lbs - 8" x 10" 115 VAC output
DL-9000PS/24 (Power Supply)	• 17 lbs - 8" x 10" 24 VDC output (Optional)
Circuitry	• Electromechanical timer, control relay and hard wire circuitry
Power Requirements	• 115 VAC, 10 AMPS
	• Motor/Pump 115VAC, 1/3 Hp, 6 Amps, Gear With Gear model 42FAR Motor must rotate clockwise with above pump
Pressure Gage/Filter	• 120- 160 psi, liquid filled, in-line
Lubricant Level	• Electronic sensor with red indicator on all tanks
	• Clear top mounted barrel gage on all tanks
Paint/Color	• Powder/Burgundy with gray logo
Lubricant Viscosity	• Approx. range: 30 - 500 SSU at 100 F

4.0 SEQUENCE OF OPERATIONS

4.1 LUBRICANT TANKS WITHOUT DL-9000 POWER SUPPLY. In the "OFF CYCLE" mode, the channels' valve(s) will not operate, although the detection sensor will still operate. An LED indicator on the sensor will signify the sensor is operating properly. The supply tubing (nylon, steel, copper, etc) connecting the tank to the solenoid valves will have 20 - 25 psi of lubricant pressure. A check valve at the tank will maintain this psi in the "OFF CYCLE" mode.

4.2 When a lubrication cycle is about to begin (actually 8 sensor activation's prior to operation), the pump/motor will start and maintain lubricant pressure to the valve(s) throughout the lubrication cycle. Each time a sensor is activated, the valve will dispense lubricant onto the desired point(s). After completion of the lubrication cycle, the valve(s) will deactivate to normally closed. The pump/motor will continue to run for approximately five minutes (5) and shut off.

4.3 During a lubrication cycle, if the conveyor stops, the pump/motor will run for approximately five minutes (5) then shut off. Once the conveyor restarts and the channels sensor activates the pump/motor will restart.

4.4 If the lubricant tank's lubricant level runs low, the pump/motor will also shut off and the red indicator lamp will turn on at the DL-5003HC. The DL5003HC will turn off sensors and valves, and a screen will also indicate the following flashing message: OUT OF LUBRICANT. Once the tank is refilled with lubricant, the lamp will turn off, the pump/motor will turn on and the DL-5003HC will resume lubricating where it left off in the "ON CYCLE" mode. **Note: If intermittent power loss occurs, the DL-5003HC will retain its memory count in the program.**

DIGILUBE PROGRAMMABLE LUBRICATION SYSTEM INSTALLATION / OPERATIONAL MANUAL

4.5 LUBRICANT TANKS WITH DL-9000 POWER SUPPLY. The DL-9000 Power Supply is designed to be trouble free and easy to install. Once the electrical hook ups and Low Pressure level Switch and High Pressure Level Regulator settings are adjusted, the DL-9000PS functions automatically.

4.6 The DL-9000 Power Supply supports three peripherals. A Low Pressure Level Switch, a High Pressure Level Regulator, and a low level switch. The Low Pressure Level Switch turns on the pump/motor when the lubricant pressure in the supply tubing drops to its **Lowest PSI** setting. The High Pressure Level Regulator maintains the lubricant pressure in the supply tubing to its **Highest PSI** setting. The low level switch prevents the pump/motor from running and allowing air into the line when the tank is low on lubricant.

4.7 When using THIN FILM lubricants, the High Pressure Level Regulator is factory-set between 25 - 35 PSI, depending on the length and elevation of supply tubing from the tank to the lubricator(s) and the number of solenoid valve(s) in the system. The Low Pressure Level Switch is set 8-10 PSI lower than the High Pressure Level Regulator.

4.8 When all channels in the system are in the "OFF CYCLES" (NON-LUBRICATION MODE) the pump/motor is off. The lubricant pressure in the supply tubing is maintained at the High Pressure Level Regulator setting of 25 - 35 PSI by a check valve at the lubricant tank. The solenoid valve(s) will not be operating although the LED sensor(s) will be counting each detection.

4.9 When a channel's "OFF CYCLES" reaches 0000, it goes into a lubrication cycle. As the valve(s) open and close, the lubricant pressure in the supply tubing begins to drop. Once it reaches the Low Pressure Level Switch setting the pump/motor turns on. The pump/motor will continue to run until the High Pressure Level Regulator setting has been maintained for 25 minutes. Once this occurs, the pump/motor will turn off, indicating that the solenoid valve(s) have been closed for that period of time.

4.10 The pump/motor will also turn off if the lubricant tank runs low of lubricant and a red indicator lamp on the DL-9000 Power Supply turns on. Filling the tank will automatically restart the pump/motor and turn off the red lamp.

4.11 The pump/motor will shut down if one of three situations are present:

- The channel(s) on the DL-5003HC have completed their lubricant cycle(s),
- Conveyor has stopped for more than 25 minutes .
- The fluid level in the tank is low.

5.0 INDICATOR LAMPS

5.1 GREEN LAMPS

Indicates power to the DL-5003HC or DL-9000PS. This lamp will be on at all times, except during power loss.

5.2 YELLOW LAMPS

DIGILUBE PROGRAMMABLE LUBRICATION SYSTEM INSTALLATION / OPERATIONAL MANUAL

Indicates the pump/motor is running and a request for lubricant from a lubricator has occurred.

5.3 RED LAMP

Indicates the lubricant tank is low of lubricant. The red lamp also indicates the pump/motor have automatically shut down to prevent air from getting into the supply tubing. The red lamp will automatically turn off and the pump/motor will restart when the lubricant tank is refilled. **NOTE: The red lamp on the DL-5003HC does not operate when used with a DL-9000PS. The red lamp on the DL-9000PS will operate along with the green and yellow lamps. Optional rotating tower indicators are also available.**

6.0 INSTALLATION

6.1 SITE SELECTION

The best location for a lubricator on a conveyor with a washer/oven is on a straight level section of rail between the load and unload area there are no parts are present. However, many times the load & unload area is the same place and where people are also working. The next best location would be after the raw parts are loaded before the washer. If lubricant does drip on a part it is washed off prior to painting. If the installation is before the washer a minimum of fifty (50) feet is required before the conveyor enters the washer. It is very important that the conveyor chain be properly protected in the washer.

6.2 Mount at a point on the conveyor that ensures chain stability and that the chain is under tension. Vibration should be minimal and bearings should be rolling as they pass the lubricator. Avoid unstable or hazardous environments like high temperatures, water or chemical exposure.

6.3 We recommend that the DL-806 & DL-812 Lubricant Tank be located on a structural column waist high for ease of filling, When using a 65 gallon tank with multiple lubricators centralize the tank within the circumference of the lubricators and out of high traffic fork truck areas.

7.0 MOUNTING THE LUBRICATOR

7.1 An enclosed track lubricator comes mounted on a 28" track rack and a Monorail I-Beam lubricator comes pre-mounted on a track 24" section of I-Beam for ease of installation. The lubricator can also be installed on the customers' existing conveyor and is usually done by a contractor or a Digilube Systems Service Representative.

8.0 MOUNTING DL-806 & 812 LUBRICANT TANKS

8.1 DL - 806 LUBRICANT TANK - 6 - GALLON

The DL-806 can be installed at a remote location for ease of filling or on conveyor rail right behind the lubricator. For other pumping stations please refer back to **6.5**

DIGILUBE PROGRAMMABLE LUBRICATION SYSTEM INSTALLATION / OPERATIONAL MANUAL

8.2 If the tank is mounted with the lubricator, weld pre-mounted track section in place and connect to 115VAC, 10 AMP continuous power source.

8.3 For remote installation, locate tank as mentioned in **6.5**. **All Lubricant Tank w/o DL-9000 Power Supply require that the power source (115vac) be run from the lubricator back to the lubricant tank.** When installing nylon tubing push the tubing firmly and as far as possible into the quick-connect fitting located next to the motor on the tank. Make sure the proper connection is made by pulling back on the tubing. This will lock-in the tubing. The supply tubing is fastened to the electrical conduit connecting the tank to the lubricator with wire ties. The tubing can also be connected to overhead building structural members with wire ties or beam clamps. Sharp bends in the supply tubing will slow or stop lubricant flow and must be avoided. To remove the tubing, push in on the fitting collar while pulling out on the tubing. The self-locking fitting is reusable. The nylon tubing is usually 1/4" O.D. However, steel or copper tubing should be used for high-temperature service, which will require different fittings.

8.4 If there is power to the DL-5003HC the red lamp will be on. Once the tank is filled with lubricant the red lamp will turn off.

9.0 MOUNTING LUBRICANT TANKS WITH DL-9000 POWER SUPPLY (OPTIONAL)

9.1 Locate the Lubricant Tank in a protected area to avoid damage. **Please refer back to 6.5**

9.2 The DL-9000PS Power Supply must be connected to the incoming 115VAC, 10 AMP power source.

9.3 The Low Pressure Level Switch is set at the factory to match the High Pressure Level Switch setting. Should the pressure loss drop to the LPLS setting, it will close and signal the DL-9000PS to start the pump/motor. The LPLS setting must be checked and possibly changed if the HPLR setting is changed.

9.4 To adjust the Low Pressure Level Switch, turn the thumb wheel clockwise to increase pressure loss required to start the pump/motor. Turn the thumb wheel counterclockwise to decrease the pressure loss required to start the pump/motor. You may test the Low Pressure Level Switch adjustments by leaving one lubricator in a lubrication mode and observe the pressure gauge at the lubricant tank. When the pump/motor is operating and the desired high pressure is reached, push the "System Reset" toggle inside the DL9000 Power Supply and the pump/motor will stop. If the adjustment is correct, the pump/motor will not start until the pressure drops to Low Pressure Level Switch setting which will then restart the pump/motor. The pump/motor turns on but the pressure is to low the thumb wheel clockwise to increase the pressure loss required to restart the pump/motor.

10.0 POWER CONNECTIONS

DIGILUBE PROGRAMMABLE LUBRICATION SYSTEM INSTALLATION / OPERATIONAL MANUAL

10.1 DL-806 LUBRICANT TANK - 6 GALLON MOUNTED W/ LUBRICATOR

Connect incoming power to hot, neutral, and ground to J19 on the DL-5003HC's terminal strip.

10.2 DL-806 - LUBRICANT TANK - 6 GAL FROM A REMOTE LOCATION

If the tank is installed at a remote location, run five (5) 14 gauge wires (1 black, 1 white, 1 green, 2 red) from the DL-5003HC to the motor and float. At the DL-5003HC's terminal strip, the black and white wires connect to J13 and the two red wires connect to J7. At the Tank, connect the two red wires to the two yellow float switch wires. Connect the black and white wires to the motor leads for **low voltage - 115 VAC**. Connect incoming power to hot, neutral, and ground to J19 on the DL-5003HC's terminal strip.

10.3 DL-865 LUBRICANT TANK - 65 GALLON W/ DL-9000 POWER SUPPLY

The **DL-9000PS 115VAC** output is standard. An optional **DL-9000 Power Supply /24VDC** is also available. Both Power Supplies require 115VAC input. Connect the DL-9000 Power Supply to a continuous power source. Please consult Digilube System to determine which method is best for your conveyor.

10.4 DL-5003HC INPUT REQUIREMENTS CONNECTED TO DL9000PS/115VAC

When using a pumping station with a DL-9000 Power Supply /115VAC, no electrical connection is required between the DL-5003HC and the pumping station. However a 115VAC 10 amp drop is required to each DL-5003HC.

10.5 DL-5003HC INPUT REQUIREMENT CONNECTED TO DL-9000PS/24 VDC

Electrical connects between DL-5003HC and DL-9000 Power Supply / 24VDC output is as follows: Connect two strand 18 gauge shielded wire to J18 on DL-5003HC's terminal strip and to 11 & 12 on DL-9000 Power Supply /24 VDC's terminal strip. See diagrams & illustrations at **18.8, & 18.9**.

11.0 DL-5003HC DEFINITIONS

The Digilube system is controlled by the DL-5003HC. This microprocessor-based circuitry has four (4) independent channels which provide the user with the ability to insert the desired lubrication settings and to change settings whenever required while in the field. The DL-5003HC will automatically read these settings and incorporate them into its' performance.

11.1 "LINK MODE" DEFINITION

There are two ways of programming the DL-5003HC, either by LINK or by TIME. The LINK mode is used with a detection sensor. The sensor reads objects which pass in front of it like trolley wheels, chain pin links, rollers, etc. In a lubrication cycle, the sensor, when activated, will open up a solenoid valve and dispense lubricant. In both lubrication and non-lubrication modes, the sensor will count the number of objects which will then be processed by the DL-5003HC. Once programmed, the DL-5003HC will input these detections and lubricate accordingly.

DIGILUBE PROGRAMMABLE LUBRICATION SYSTEM INSTALLATION / OPERATIONAL MANUAL

11.2 "TIME MODE" DEFINITION (USED ONLY IN MACHINE APPLICATIONS)

The TIME mode is used without any sensors. It functions on TIME only. The user determines when and how much lubricant will be dispensed at a given lube point. This mode is used on high speed chains, stationary lube points like sprockets and on machines.

11.3 "OFF CYCLE" DEFINITION

In the LINK mode, the "OFF CYCLE" means the number of completed cycles of the conveyor in a non-lubrication mode. EXAMPLE: A conveyor 300 feet long, traveling 600 feet during a non-lubrication mode has completed TWO "OFF CYCLES".

11.4 "# of Links / # of On Counts" DEFINITION

The "# of LINKS" (LINK mode) # of ON COUNTS (TIME mode) means the total number of trolley wheels, center links, rollers, etc that make up a complete cycle of the conveyor. This is also the number of valve activations which will occur in the during a lube cycle of the program. When a lube cycle begins, the "OFF COUNT" is at zero (0000). In the TIME mode, this also corresponds to the number of shots of lubricant in the lube cycle.

11.5 TO DETERMINE "ON COUNT" FOR FORGED LINK X-CHAIN.

Take the number of center links that the detection sensor will detect in a one foot section and multiply it by the conveyors' length in feet.

EXAMPLE (1): A conveyor 500 feet long having an X348(3") pitch chain will activate the detection sensor 2.0 times per foot of chain length. Therefore $2 \times 500 = 1000$ "ON COUNTS".

EXAMPLE (2): A conveyor 500 feet long having an X458(4") pitch chain will activate the detection sensor 1.5 times per foot of chain length. Therefore $1.5 \times 500 = 0750$ "ONCOUNTS".

EXAMPLE (3): A conveyor 500 feet long having an X678(6") pitch chain will activate the detection sensor 1.0 times per foot of chain length. Therefore $1.0 \times 500 = 0500$ "ON COUNTS".

EXAMPLE (4): An enclosed track conveyor with 6" pitch chain will activate the detection sensor 2.0 times per foot of chain length. Therefore $2.0 \times 500 = 1000$ "ON COUNTS".

EXAMPLE (5): An enclosed track conveyor with 8" pitch chain will activate the detection sensor 1.5 times per foot of chain length. Therefore $1.5 \times 500 = 0750$ "ON COUNTS".

11.6 "VALVE TIME SETTING" DEFINITION

This determines the amount of time the solenoid valve(s) will be open. The longer the valve is open the more lubricant will be dispensed. A setting of 0000 is off. A 0.001 is required for the valve to function properly and will dispense the least amount of lubricant and a 9.999 will dispense the largest amount.

EXAMPLE SETTINGS: **Please keep in mind every conveyor and application is different. The settings listed below are good starting points - check your chain and trolleys frequently making changes as needed**

X348 CHAIN PINS 0004 TROLLEYS 0008
X458 CHAIN PINS 0006 TROLLEYS 0012

DIGILUBE PROGRAMMABLE LUBRICATION SYSTEM INSTALLATION / OPERATIONAL MANUAL

X678 CHAIN PINS 0008 TROLLEYS 0016
UNIBILT/RAPID CHAIN 0001 TROLLEYS 0001

11.7 DELAY TIME DEFINITION

The DELAY TIME indicates the amount of time the DL-5003HC will not accept another input from the detection sensor, thus preventing multiple shots of lubricant at the points to be lubricated. Generally a setting of 0500 or .5 sec will be sufficient however, when sensing an irregular casting or multiple wheels (such as a free trolley carrier) this setting will need to be increased to cover the entire field of the object.

11.8 "CONFIGURE MODE" DEFINITION

THE CONFIGURE MODE allows the user to change the four digit PIN security code. This number keeps unwanted changes to the programmed settings. This mode also allows user to change the real-time clock for the TIME mode portion of the DL-5003HC. This allows for time zone differences and time drift over a period of years. This mode can also change the baud rates (ASCII COMMUNICATION) if an optional modem is used. Press "C" to enter configuration mode and follow on screen instructions.

11.9 "TEST MODE" DEFINITION

THE TEST MODE enables the users to override the programming of the DL-5003HC. Each channel can be enabled or disabled, to manually open and or close a solenoid valve or to put into a continuous lube cycle for routine preventive maintenance requirements. See 15.0 for detailed operation

11.10 "FORCE LUBE CYCLE" DEFINITION

The FORCE LUBE CYCLE zero's the OFF COUNTS. This will force a lube cycle on the next sensor detection. After the lube cycle has been completed, the channel will automatically return to its programmed OFF CYCLES. See 15.0 for detailed operation

11.11 PIN SECURITY CODE

In order to program the DL-5003HC, it is necessary to know the four-digit PIN security code. This will enable the user to restrict the number of people authorized to maintain the equipment and to change program settings. The code is preset at the factory at 0000. See 14.0 on Configure mode for instructions on setting a different security code.

12.0 PROGRAMMING LINK MODE

Programming the DL-5003HC is very easy if a few things are kept in mind.

- Press "A" once for Program Mode
- Press "A" twice for Test Mode
- Press "B" to Force Lube Cycle
- Press "C" for Configure Mode

12.1 While programming a channel, remember the following:

- Press "A" to advance screens
- Press "D" anytime to return to Main Screen
- Follow the Screen Prompts
- When changing values, press * button to save the new values

DIGILUBE PROGRAMMABLE LUBRICATION SYSTEM INSTALLATION / OPERATIONAL MANUAL

12.2 MAIN COUNT SCREEN	CH1	CH2	CH3	CH4
OFF COUNTS	0000	0000	0000	0000
NUMBER OF LINKS	0000	0000	0000	0000

12.3 EXAMPLE STEP BY STEP PROGRAMMING LINK MODE FOR I-BEAM CONVEYORS

The following example will take you step by step on programming **CHANNEL #1 to lubricate the chain pins** on a monorail I-Beam conveyor. You have a 4" Monorail I-Beam conveyor with X458 chain links and it is a 1000'L. You want to lubricate the chain pins every fifth cycle and you want to dispense a small amount of lubricant. The valve has two .031 I.D. dispensing tubes and you have determined the pressure at the solenoid valve is 30 PSI.

12.4 CHANNEL ASSIGNMENT(S)

Monorail I-Beam Lubricator

CH1 – Chain pins

CH2 – Open trolley wheels

CH3 – Cat drive chain/swivel

CH4 – Free carrier

Enclosed Track Lubricator

CH1 – Vertical Wheels

CH2 – Pins and Horizontal Wheels

CH3 – Cat Drive

CH4 – Free Carrier

DL5003HC PROGRAMMING

Please refer to above channel assignments

MAIN SCREEN ON

POWER UP

BY PRESSING "D" ANYTIME
RETURNS YOU TO MAIN SCREEN

PRESS " A "

"PROGRAM MODE"

PRESS "*" TO ENTER PROGRAM MODE
PRESS "A" TO ENTER TEST MODE

PRESS "*" AND SCREEN WILL READ
PLEASE ENTER YOU PIN NUMBER
(Factory preset 0000) screen will display

DL5003 HC REV 1.2
DIGILUBE SYSTEMS

0 0 0 0 0 0 0 0 0 0 0 0 0 0 0 0
0 0 0 0 0 0 0 0 0 0 0 0 0 0 0 0

13:24:41

PRESS * TO ENTER PROGRAM MODE
PRESS A TO ENTER TEST MODE

PLEASE ENTER ENTER PIN #

_ _ _

DIGILUBE PROGRAMMABLE LUBRICATION SYSTEM INSTALLATION / OPERATIONAL MANUAL

"XXXX"

DL5003 HC

IF INCORRECT PIN # ENTERED
SCREEN WILL READ

INCORRECT PIN # PRESS "A" TO ESCAPE

DL5003HC

PRESS "A"
AND SCREEN RETURNS TO
MAIN SCREEN
YOU MUST START AGAIN

0 0 0 0 0 0 0 0 0 0 0 0 0 0 0 0
0 0 0 0 0 0 0 0 0 0 0 0 0 0 0 0

13:24:41

PRESS "A"
PRESS "*" TO ENTER PROGRAM MODE
PRESS "A" TO ENTER TEST MODE

PRESS * TO ENTER PROGRAM MODE
PRESS A TO ENTER TEST MODE

ENTER CORRECT PIN NUMBER NOW
PRESET TO "0000" FROM
MANUFACTURER

PLEASE ENTER PIN #

DL5003 HC

WHEN CORRECT PIN # IS ENTERED
YOU WILL SEE THIS SCREEN

CORRECT PIN NUMBER PRESS * TO
CONTINUE

DL5003HC

PRESS "*" AND SCREEN WILL READ
YOU MUST SELECT WHICH CHANNEL YOU
WISH TO PROGRAM NOW

SELECT CHANNEL TO
PROGRAM (1-4) —
PRESS A TO CONTINUE

DL5003 HC

PRESS "A"

HERE IS WHERE YOU CHOOSE **LINK** OR
TIME MODE. WE WILL GO INTO **LINK** MODE
NOW.

CH 1 OPERATION MODE
LINK MODE
PRESS * TO DISABLE, ** FOR TIME MODE
PRESS A TO CONTINUE

DIGILUBE PROGRAMMABLE LUBRICATION SYSTEM INSTALLATION / OPERATIONAL MANUAL

LINK PROGRAM MODE

PRESS "A"

ENTER THE NUMBER OF OFF CYCLES
(COMPLETE REVOLUTIONS OF THE
CONVEYOR WITHOUT LUBRICATING

PRESS "*" TO SAVE

CH 1 # OF OFF CYCLES

PRESS * TO SAVE

PRESS A TO CONTINUE

PRESS "A" TO CONTINUE

ENTER NUMBER OF LINKS (THE NUMBER OF
TARGETS YOUR SENSOR WILL PICK-UP)

PRESS "*" TO SAVE

CH 1 # OF LINKS

PRESS * TO SAVE

PRESS A TO CONTINUE

PRESS "A" TO CONTINUE

ENTER VALVE TIME. A SETTING OF
0001 IS THE MINIMUM SETTING.
A SETTING OF 0001-0003 IS NORMAL
FOR ENCLOSED TYPE CONVEYORS.

PRESS "*" TO SAVE

CH 1 VALVE TIME SETTING

PRESS * TO SAVE

PRESS A TO CONTINUE

PRESS "A" TO CONTINUE

ENTER DELAY TIME NOW
THIS KEEPS A SHAKING CONVEYOR
FROM INPUTTING TWICE ON THE SAME
INPUT. PRESS "*" TO SAVE

CH 1 DELAY

(MSEC)

PRESS * TO SAVE

PRESS A TO CONTINUE

PRESS "A" TO CONTINUE

12.5 FROM THE MAIN COUNT SCREEN

You have just completed programming Channel 1, press "A" and program the remaining channel(s) or press "D" to return to the Main Count Screen.

BY PRESSING "A" YOU RETURN TO THE
FIRST PROGRAMMING SCREEN. YOU
MUST NOW CHOOSE ANOTHER
CHANNEL OR YOU WILL SCROLL THRU
PREVIOUS CHANNEL'S SCREENS.

SELECT CHANNEL TO

PROGRAM (1 - 4)

PRESS A TO CONTINUE

DL5003 HC

DIGILUBE PROGRAMMABLE LUBRICATION SYSTEM INSTALLATION / OPERATIONAL MANUAL

PRESS "D" TO ESCAPE

THIS RETURNS YOU TO THE MAIN

SCREEN

ALWAYS FOLLOW SCREEN INSTRUCTIONS

```
0000 0000 0000 0000
0000 0000 0000 0000
```

13:24:41

13.0 PROGRAMMING TIME MODE

The TIME MODE is used to lubricate, sprockets, and/or high speed chains where a sensor(s) cannot be used and on a wide variety of machines.

MAIN COUNT SCREEN

00 DAYS 00 HOURS
00 MIN. 00 SEC

CH1 CH2 CH3 CH4

0000 0000 0000 0000
0000 0000 0000 0000

13.1 In the TIME MODE the user programs the channel for CYCLE TIME which indicates the time between lubrication cycles, ON COUNTS which indicates the number of shot of lubricant, LUBE TIME which determines how long the valve remains open, DURATION BETWEEN which indicates the length of time between each shot of lubricant.

TIME PROGRAM MODE

THE TIME PROGRAM MODE IS AN ELAPSE
TIMER IN THIS EXAMPLE WE WILL LUBRIATE
EVERY 8 HRS AND 30 MINUTES.

PRESS "A" THEN PRESS "*" AND
ENTER CORRECT PIN NUMBER NOW
(Preset to "0000" FROM THE MANUFACTURER
as you are entering correct pin number
screen will read "XXXX"
WHEN CORRECT PIN # IS ENTERED
YOU WILL SEE THIS SCREEN

PLEASE ENTER ENTER PIN #

DL5003 HC

CORRECT PIN NUMBER PRESS * TO
CONTINUE

DL5003HC

PRESS "*" AND SCREEN WILL READ
YOU MUST SELECT WHICH CHANNEL
YOU WISH TO PROGRAM NOW

SELECT CHANNEL TO
PROGRAM (1-4) ----
PRESS A TO CONTINUE

DL5003 HC

PRESS "A" TO CONTINUE

CHOOSE LINK OR TIME MODE.
TO ENTER TIME MODE. PRESS "*"
TO DISABLE LINK MODE

CH1 OPERATION MODE * TO TOGGLE
TIME MODE
PRESS * TO DISABLE , #* TO LINK MODE
PRESS A TO CONTINUE

DIGILUBE PROGRAMMABLE LUBRICATION SYSTEM INSTALLATION / OPERATIONAL MANUAL

PRESS "A" TO CONTINUE

DAY/HOUR/MIN/SEC
ENTER CYCLE TIME
PRESS "*" TO SAVE

00: 00 :00 :00:
ENTER CYCLE TIME
PRESS "*" TO SAVE
PRESS "A" TO CONTINUE

PRESS "A" TO CONTINUE

ENTER # OF ON COUNTS (LINKS)
PRESS "*" TO SAVE

CH1 # OF COUNTS
PRESS "*" TO SAVE ----
PRESS "A" TO CONTINUE

PRESS "A" TO CONTINUE

VALVE SETTING
DESIRED SHOT OF LUBRICANT IN
EACH PULSE
PRESS "*" TO SAVE

CH1 VALVE SETTING
PRESS "*" TO SAVE ____
PRESS "A" TO CONTINUE

PRESS "A" TO CONTINUE

ENTER DELAY TIME BETWEEN
SHOTS PRESS "*" TO SAVE

CH1 DURATION OF SHOT
PRESS "*" TO SAVE ____
PRESS "A" TO CONTINUE

PRESS "A" TO CONTINUE

**YOU HAVE JUST COMPLETED CH1
CONTINUE PROGRAMMING FOR
ALL CHANNELS**

13.2 One channel has been programmed in the TIME MODE. Select another channel or Press "D" to return to MAIN COUNT SCREEN

14.0 HOW TO OPERATE CONFIGURE MODE

The CONFIGURE MODE allows user to change PIN security codes, Real Time Clock (in the Time Mode only) and choose different Baud Rates for the optional ASCII Communication.

15.0 HOW TO OPERATE TEST MODE

DIGILUBE PROGRAMMABLE LUBRICATION SYSTEM INSTALLATION / OPERATIONAL MANUAL

The TEST MODE allows the user to enable/disable any channel, open/close any valve or begin a continuous lube cycle.

15.1 EXAMPLE 1: Screen One – Enable/Disable a channel. This feature is used primarily during installation and is routine maintenance checks. When adjusting the dispensing tubes for the first time, it allows the installer, to remove air from the supply line(s) and/or to adjust the dispensing tubes, one valve at a time. This reduces an accumulation of lubricant on the rail, floor, parts, etc from misdirected dispensing tubes.

- From the Main Count Screen, Press “A” twice to enter Test mode and enter PIN #
- Press “*” once to advance screen Enter appropriate channel.
- Press * to Enable channel
- Press “D” to return to Main Count Screen

15.2 EXAMPLE 2: Screen two – Open/Close a Valve. This feature is used mainly during installation/startup to bleed air out of the nylon supply tubing, or whenever air is trapped in the tubing.

- From the Main Count Screen, Press “A” twice to enter Test mode
- Enter appropriate channel
- Press “A” twice to advance the screen to Open/Close
- Press * to Open Valve,
- Press * again to Close Valve
- Press “D” to return to Main Count Screen

15.3 EXAMPLE 3: Screen three – Continuous Lube. This feature will immediately put the channel into a continuous lube cycle. Use this mode if the conveyor chain is extremely dry, and you want to lube it several cycles or if the conveyor requires continuous lubrication.

- From the Main Count Screen, Press “A” twice to enter Test mode
- Enter appropriate channel
- Press “A” three times to advance the screen to Continuous Lube
- Press “*” to read YES. The selected channel will now lubricate continuously
Press “D” to return to Main Count Screen

MAIN SCREEN ON
POWER UP

DL5003 HC REV 1.2
DIGILUBE SYSTEMS

BY PRESSING "D" ANYTIME
RETURNS YOU TO MAIN SCREEN

0 0 0 0 0 0 0 0 0 0 0 0 0 0 0 0
0 0 0 0 0 0 0 0 0 0 0 0 0 0 0 0

13:24:41

DIGILUBE PROGRAMMABLE LUBRICATION SYSTEM INSTALLATION / OPERATIONAL MANUAL

"TESTMODE"

PRESS "*" TO ENTER PROGRAM MODE
PRESS "A" TO ENTER **TEST MODE**

PRESS * TO ENTER PROGRAM MODE
PRESS A TO ENTER **TEST MODE**

PRESS A TO CONTINUE

PRESS "*"
ENTER CORRECT PIN NUMBER NOW
(Preset to "0000" FROM THE MANUFACTURER
as you are entering correct pin number
screen will read "XXXX"

PLEASE ENTER ENTER PIN #

DL5003 HC

WHEN CORRECT PIN # IS ENTERED
YOU WILL SEE THIS SCREEN

CORRECT PIN NUMBER PRESS * TO
CONTINUE
DL5003HC

PRESS "*" TO CONTINUE IN TEST MODE

TO ENABLE OR DISABLE ANY CHANNEL
(CHOOSE CH NOW) **PRESS "*" THIS**
ALLOWS YOU TO PERFORM ANY INDIVIDUAL
NECESSARY WORK ON AN CHANNEL
DURING SET-UP.

CH 1 ENABLE
"*" TO TOGGLE
DL5003HC

PRESS A TO CONTINUE

OPEN/CLOSE ANY CHANNEL (CHOOSE
CHN NOW) **PRESS "*" THIS**
THIS IS HELPFUL WHEN YOU INITIALLY
SETUP. WHEN YOU LEAVE TEST MODE
THIS FUNCTION DEFAULTS TO **CLOSED**

CH 1 VALVE CLOSED
PRESS "*" TO TOGGLE

PRESS A TO CONTINUE

Or press "D" to return to the main screen

16.0 HOW TO OPERATE THE FORCE LUBE CYCLE

The FORCE LUBE CYCLE allows the user to begin a lube cycle immediately. This is usually done if the chain looks unusually dry and you want to lube it but keep the existing program.

- Press "B" to advance screen to Force Lube Cycle

DIGILUBE PROGRAMMABLE LUBRICATION SYSTEM INSTALLATION / OPERATIONAL MANUAL

- Press * to Force Lube Cycle
- Enter appropriate channel and Press * to start

17.0 MAINTAINING THE LUBRICATION SYSTEM

The Digilube Lubrication System with the DL-5003HC is the most advanced lubricator on the market today. It will provide many years of trouble free lubrication. However, **regular maintenance is a must** to insure the equipment is operating properly, dispensing tubes properly adjusted and that the conveyor is getting the correct amount of lubricant. The plant maintenance personnel should inspect the system at least monthly if not weekly. The following maintenance steps should be adhered to closely:

17.1 Check lubricator to make sure dispensing tubes are properly adjusted. Make sure all dispensing tube outlets for each valve are at the same level to prevent dripping from lower tubes.

17.2 Inspect the sensor(s) LED for proper activation and make sure the sensor is tightly secured onto the bracket.

17.3 Inspect conveyor chain, trolleys, etc for sufficient amount of lubricant

17.4 Check and maintain a sufficient amount of lubricant in the tank to prevent automatic shutdown caused by an empty tank.

17.5 **If the maintenance department does not have the personnel to devote to maintaining the equipment, a Preventative Maintenance Service Contract by Digilube Systems or an authorized representative is recommended.**

18.0 SUGGESTED SPARE PARTS

Although Digilube Systems provides rapid response and shipping of replacement parts, we offer the following spare parts listing for the user to stock as desired:

18.1 MONORAIL LUBRICATOR

F12955	Valve, Solenoid 24 VDC
E07200-T	Sensor Inductive 24 VDC
E07200-T1	Cable for above sensor (optional)
E07100	Sensor Photo-Electric 24 VDC
F09355	Dispensing Tubes 2T-.031
OLT1	Lamps LED Indicator-28 VDC
OLT2-3	Lamps Clear – 28VDC
E06303-1	DL-5003HC replacement board*

18.2 ENCLOSED TRACK LUBRICATOR

F12955	Valve, Solenoid 24 VDC
E07200-T	Sensor Inductive 24 VDC
E07200-t1	Cable for above sensor (optional)
E09355	Dispensing Tubes 2T-.031
E09360	Dispensing Tubes 2T-.031
OLT1	Lamps LED GreenIndicator-28 VDC

DIGILUBE PROGRAMMABLE LUBRICATION SYSTEM INSTALLATION / OPERATIONAL MANUAL

OLT-2-3 Lamps Clear – 28VDC
E06303-1 DL-5003HC replacement board*

18.3 LUBRICANT TANK

OLT3 Lamp Green LED Indicator for DL9000PS 115 VAC
OLT1-LT3 LAMP CLEAR – 115V
F12557 Pump - Gear*
E06550 DL-9000PS/115 VAC Output Std Unit* (Customer must specify # of HC)
E06600 DL-9000PS/24 VDC Output Std Unit* (Customer must specify # of HC)

* Should be considered for major type systems

If five or more Lubricators are being used in critical applications, such as oven conveyors, then stocking the major spare parts should be considered.

19.0 LIMITED WARRANTY

The Digilube Lubrication System is pretested and guaranteed to be in optimum condition when it leaves our factory. The DL-5003HC is fully guaranteed against defective materials and/or workmanship for a period of thirty-six (36) months from the date of purchase.

Any portion of the DL-5003HC which fails during this period for either of the above reasons, excluding normal replacement parts such as indicator lamps, fuses, etc., will be repaired or replaced at our option, if returned prepaid to our factory. All defective parts returned for warranty service is fully inspected to determine cause of failure before warranty is approved.

All other equipment components are guaranteed against defective materials or workmanship for a period of twelve (12) months from the date of purchase. Our warranty is limited to the obligation to repair or replace our equipment only. The Warranty is parts only and does not include labor.

19.1 This warranty gives you specific legal rights and you may have other rights which vary from state to state.

19.2 The Digilube warranty will be void if any of the following conditions are found to exist relative to Digilube's equipment.

- Electronics components tampered with, or short circuited
- Damaged caused from voltage or environmental conditions exceeding the operating conditions:

Operating Temperatures	45° F minimum- 120° F maximum
Relative Humidity	5 – 90% Non Condensing

DIGILUBE PROGRAMMABLE LUBRICATION SYSTEM INSTALLATION / OPERATIONAL MANUAL

- Failure due to using lubricants that do not fall with the specified viscosity range. All non Digilube lubricants must be approved, in advance by Digilube Systems Inc. to maintain warranty coverage.

DL-322/422 MONORAIL LUBRICATOR

ITEM#	QUANTITY	PART#	DESCRIPTION
1	1	E06303	MICROPROCESSOR -DL-5003HC
2A	1	OLTC1	LAMP - 28VDC – LED GREEN
2B & 2C	1	OLT2-LT3	LAMP 28VDC – CLEAR
3	2	H14700	BRACKET, UPRIGHT
4	1	H14151	BASE PLATE 6"x10"
5	1	H14152	ARM BRACKT /ALUM TRACK
6 & 11	1	H14325	FLAT SENSOR BRACKET OR
		H14600	S SENSOR BRACKET
7	1	E07100	SENSOR, PHOTO
8A	1		DISPENSING TUBE 3T(VARIOUS SIZE)
8B	1		DISPENSING TUBE 2T(VARIOUS SIZE)
9	2	H14850	HOLD DOWNS, SINGLE
	1	H14851	HOLD DOWNS, DOUBLE
10	1 PR	F15158	OUTSIDE TUBE HOLDERS
12	1	E07200	SENROR, PROXIMITY
12A	1	E07200-1	4 POLE SENSOR CONECTOR
13	1 PR		PROTECTOR PLATES (SIZE OF RAIL)
14	2	F11850	1/4" X 1/8" PRESTO LOCK FITTING
15	1	F11950	MALE ELBOW SWIVEL 1/4"-1/8" 90D
16	2	F12955	VALVE, SOLENOID 24VDC
17	2	H14775	VALVE MOUNTING BRACKET
18	1PR	H14805	1/4 20 CLAMPS
19	2	F12150	1/8 X 10X32 DISP TUBE FITTING
20	1		MONORAIL SECTION (SIZE OF RAIL)

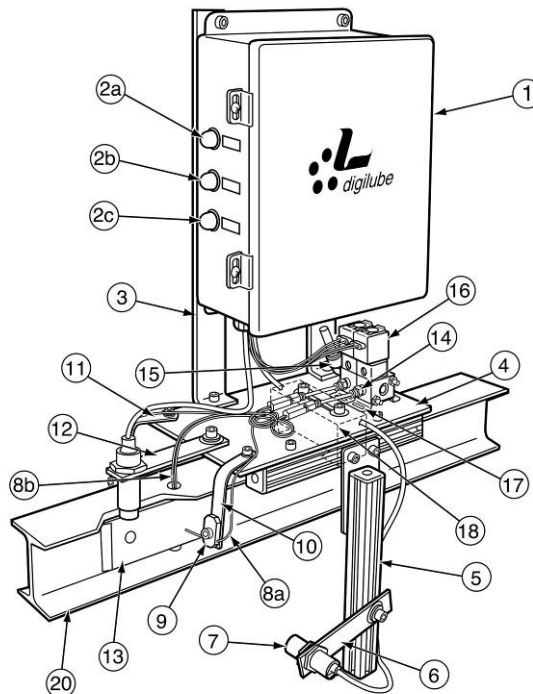

DIGILUBE PROGRAMMABLE LUBRICATION SYSTEM INSTALLATION / OPERATIONAL MANUAL

DL-122 ENCLOSED TRACK LUBRICATOR

ITEM#	QUANTITY	PART#	DESCRIPTION
1	1	E06303	MICROPROCESSOR - DL-5003HC
2A	3	OLT1C1	LAMP - LED GREEN
2B	1	OLT1C3	LAMP COVER - AMBER
2C	1	OLT1C2	LAMP COVER - CLEAR
2D	1	OLT1C1	LAMP COVER - RED
		OLT2-LT3	CLEAR LAMP 28VDC
3	1	H14700	BRACKET, UPRIGHT
4A	3	H14850	HOLD DOWNS, SINGLE
4B	2	H14851	HOLD DOWNS, DOUBLE
5A	1		DISPENSING TUBE 2T VARIOUS SIZE
5B	1		DISPENSING TUBE 3T VARIOUS SIZE
6	2	H14600	BRACKET, "S"
7	2	E07200	SENSOR, PROXIMITY HEAD ONLY
		E07200-1	CABLE FOR ABOVE SENSOR HEAD
9	2	F12050	MALE ELBOW 1/8" - 1/8" 90D
10	2	F12955	VALVE, SOLENOID 24VDC
11	1	F11950	MALE ELBOW SWIVEL 1/4" - 1/8" 90D
12	1	H15300	TRACK RACK FOR UNIBILT OR RW
13	1	H14100	BASE PLATE, MANIFOLD

MODEL

DL-111

DL-121

DL-122

DL-123

OTHER

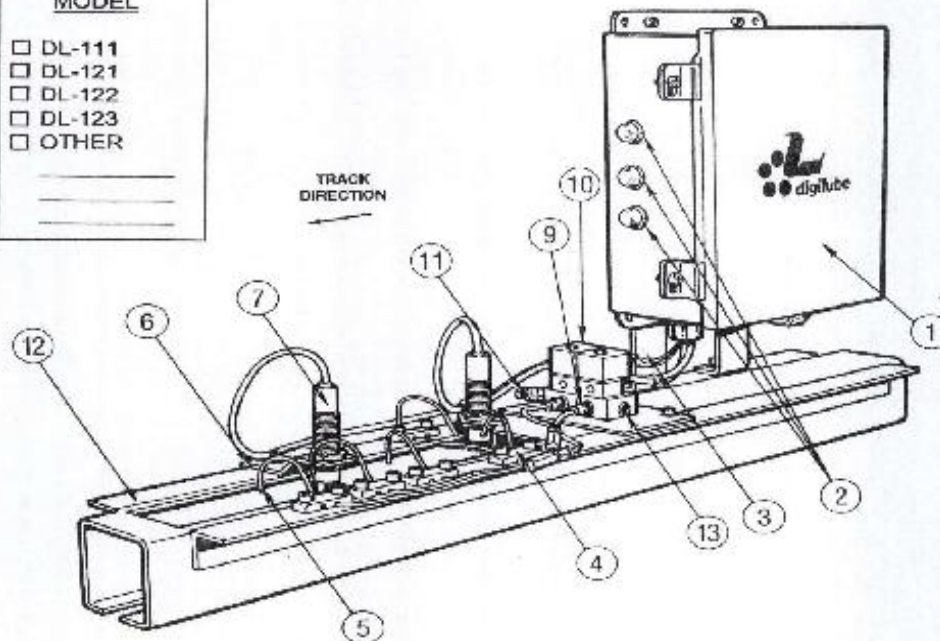

DIGILUBE PROGRAMMABLE LUBRICATION SYSTEM INSTALLATION / OPERATIONAL MANUAL

DL5003 CONTROLLER

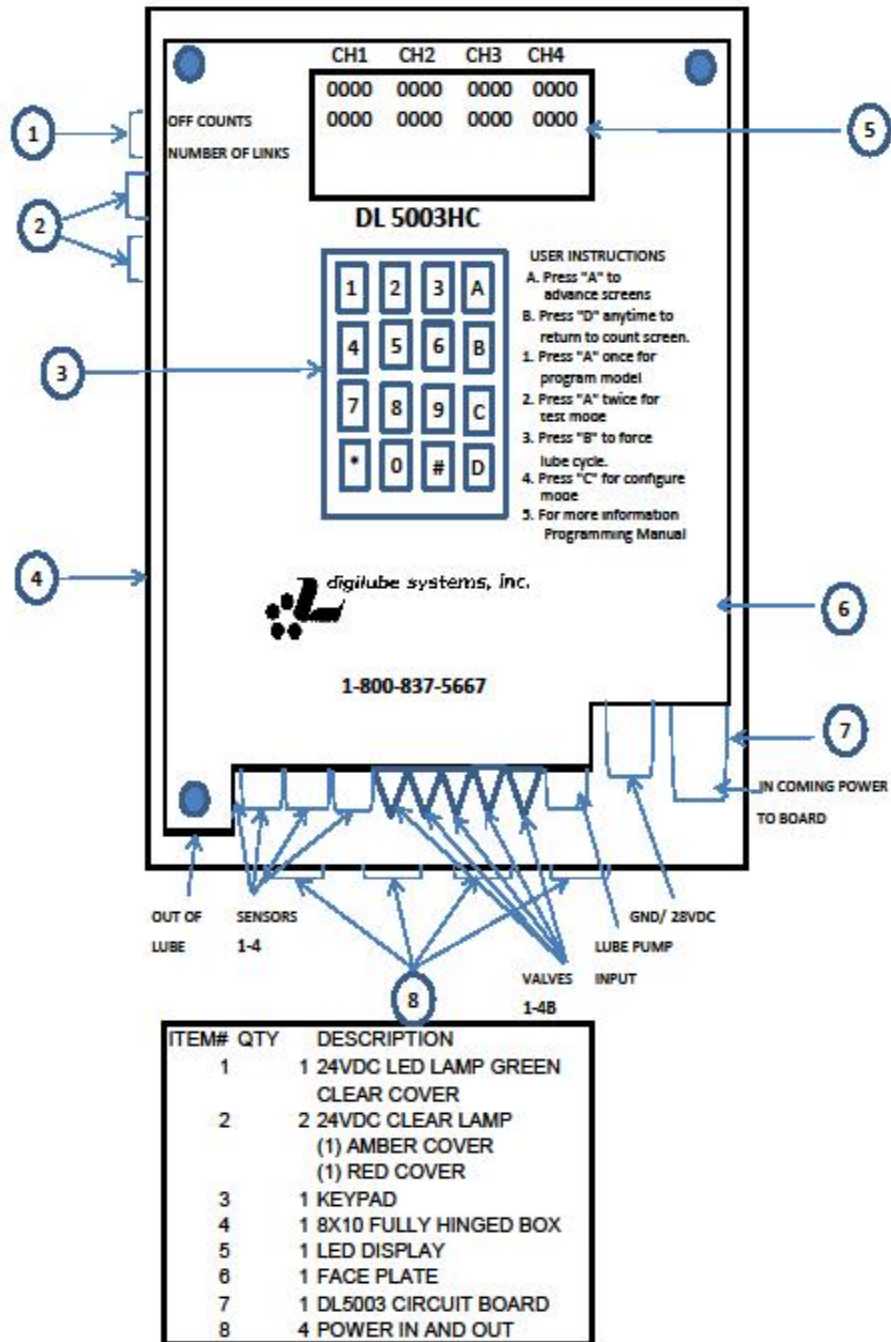

DIGILUBE PROGRAMMABLE LUBRICATION SYSTEM INSTALLATION / OPERATIONAL MANUAL

DL-5003 WIRING DIAGRAM

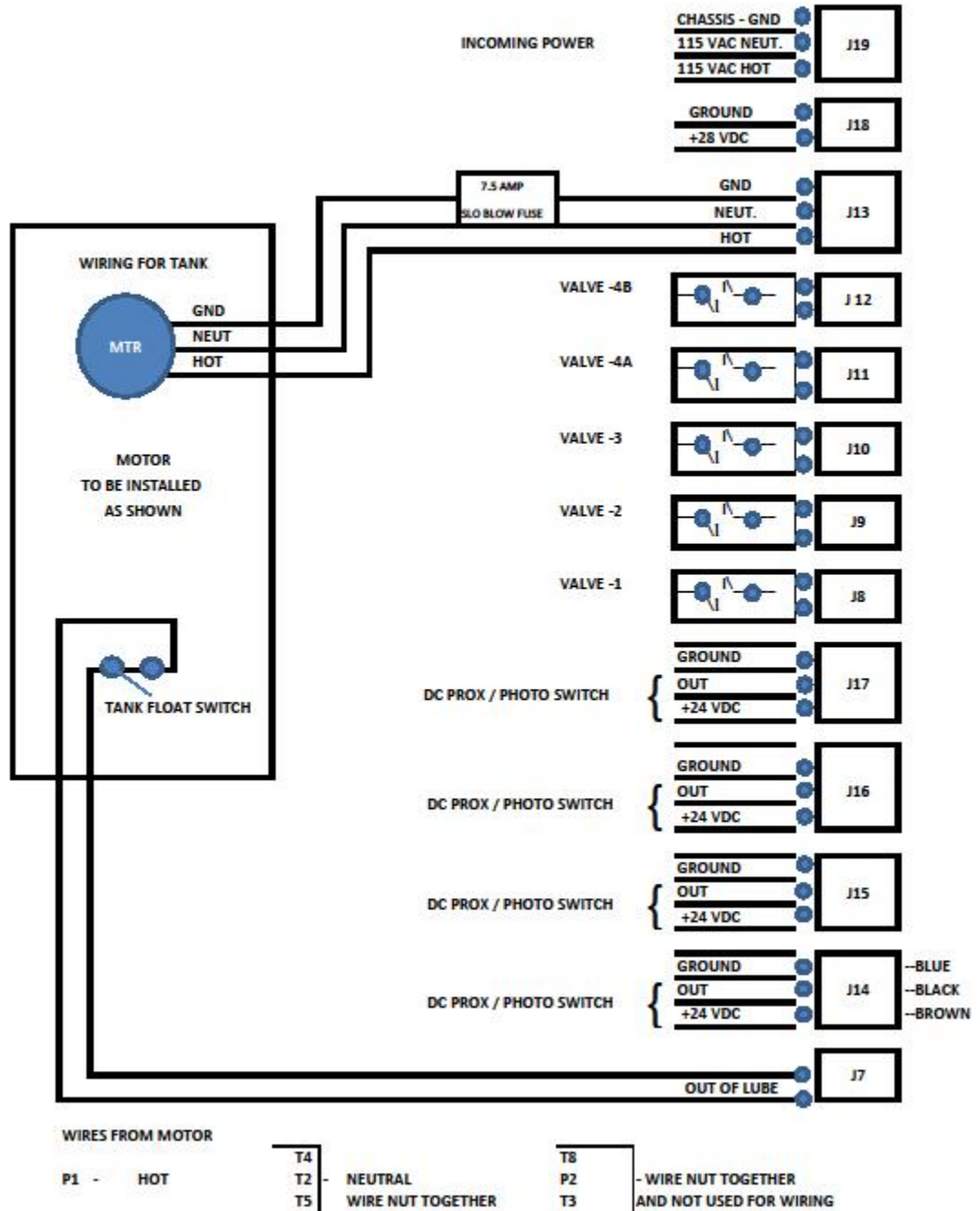

DIGILUBE PROGRAMMABLE LUBRICATION SYSTEM INSTALLATION / OPERATIONAL MANUAL

DL806 LUBRICANT TANK

ITEM#	QUANTITY	PART#	DESCRIPTION
1	1	E06400	MOTOR, 1/3 HP
2	1	F11650	MALE CONNECTOR 1/4" - 1/4"
3	1	F10900	GAUGE, PRESSURE
4	1	F09300	CHECK VALVE, 3/8"
5	1	F09200	CAP FILLER BREATHER ASSY.
6	1	F12600	STRAINER, BRASS - 1/4"
7	1	E07400	SWITCH LEVEL CONTROL
8	1	F12490	PUMP, GEAR COMPLETE INCLUDES PUMP/BELL HOUSING/COUP & BOLTS
9	2	F11100	HOSE NIPPLE, FUEL LINE, 1/4" I.D.
10	1	F13300	VALVE, PRESSURE RELIEF
11	1	F10873	BARRELL GAUGE

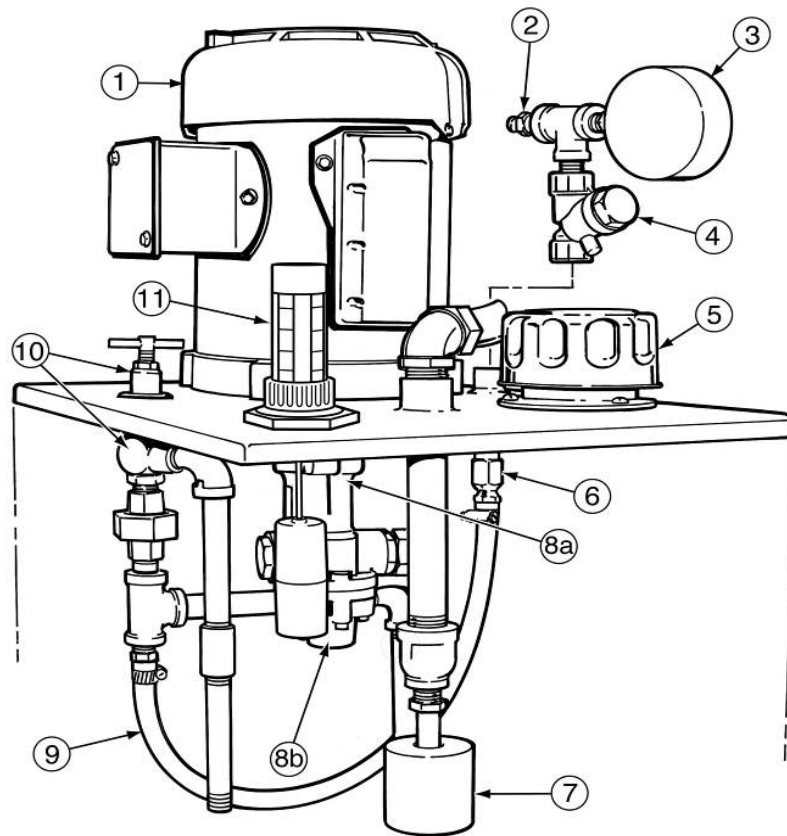

DIGILUBE PROGRAMMABLE LUBRICATION SYSTEM INSTALLATION / OPERATIONAL MANUAL

DL-865 LUBRICANT TANK

ITEM#	QUANTITY	PART#	DESCRIPTION
1A	1	E06500	POWER SUPPLY, 120/60 VAC
2	1	E06400	MOTOR 1/3 HP
3	1	E07500	SWITCH, PRESSURE
5	1	F11650	MALE CONNECTOR 1/4" - 1/4"
6	1	F10900	GAUGE, PRESSURE
7	1	F09300	CHECK VALVE, 3/8"
8	1	F09200	CAP FILLER BREATHER ASSY.
9	1	F12600	STRAINER, BRASS - 1/4"
10	1	E07400	SWITCH LEVEL CONTROL
11	1	F12490	PUMP, GEAR COMPLETE INCLUDES: PUMP/BELL HOUSING/COUP & BOLTS
12	16"	F11100	HOSE, NIIPPLE FUEL LINE, 1/4" I.D.
13	1	F13300	VALVE, PRESSURE RELIEF
14	2	H14700	BRACKET, UPRIGHT
15	1	F10875	BARRELL GAUGE

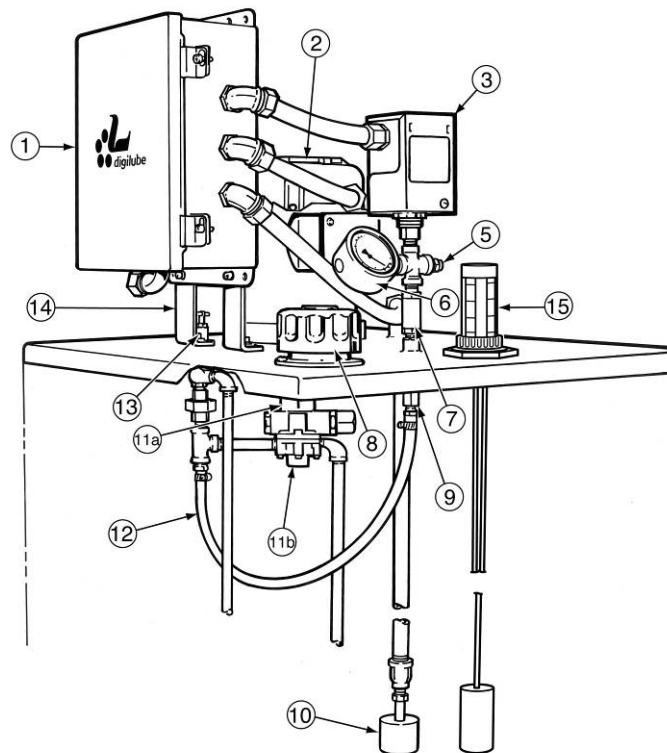

DIGILUBE PROGRAMMABLE LUBRICATION SYSTEM INSTALLATION / OPERATIONAL MANUAL

DL-9000 POWER SUPPLY

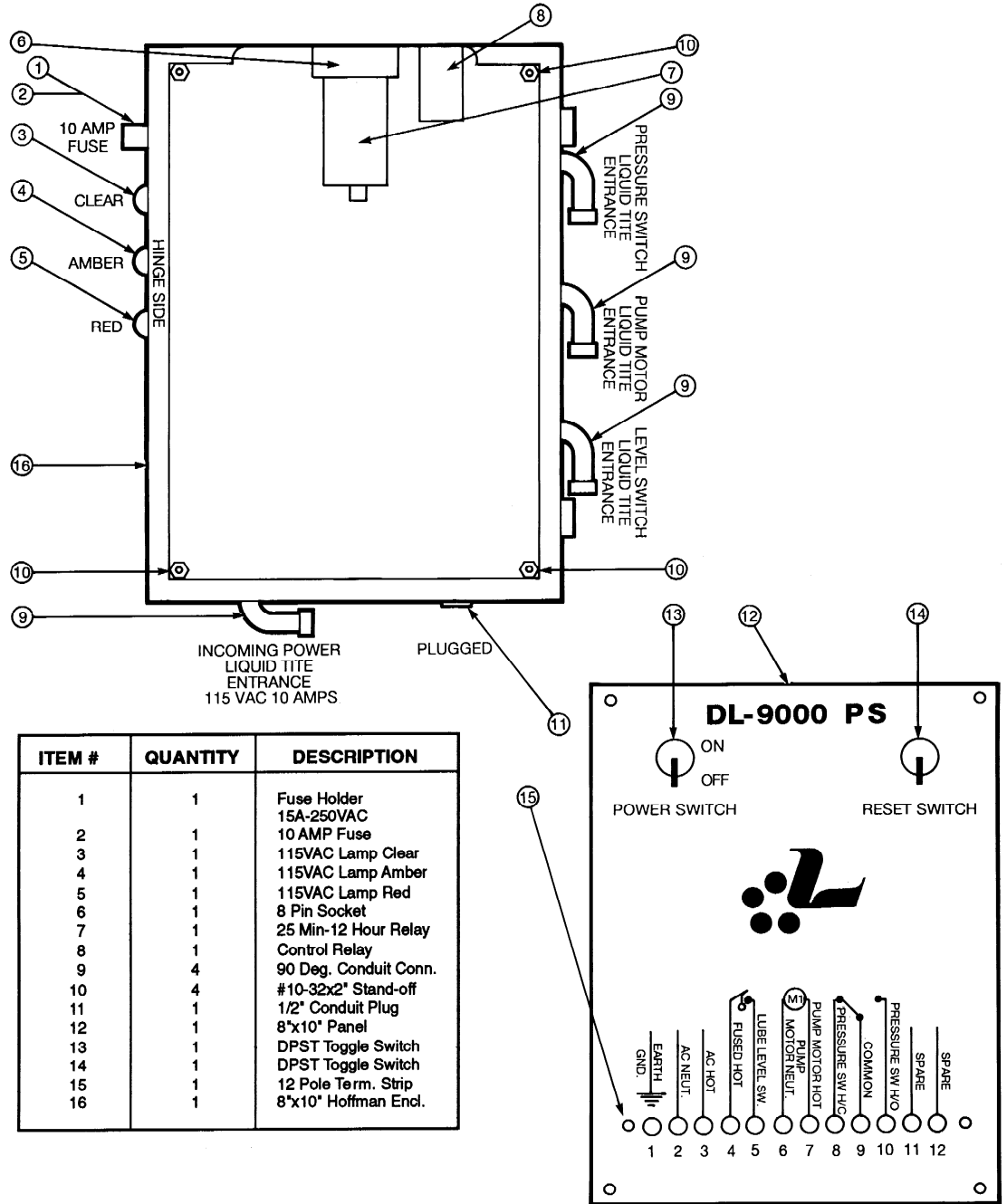

DIGILUBE PROGRAMMABLE LUBRICATION SYSTEM INSTALLATION / OPERATIONAL MANUAL

DL9000 POWER SUPPLY WIRE DIAGRAM 115VAC

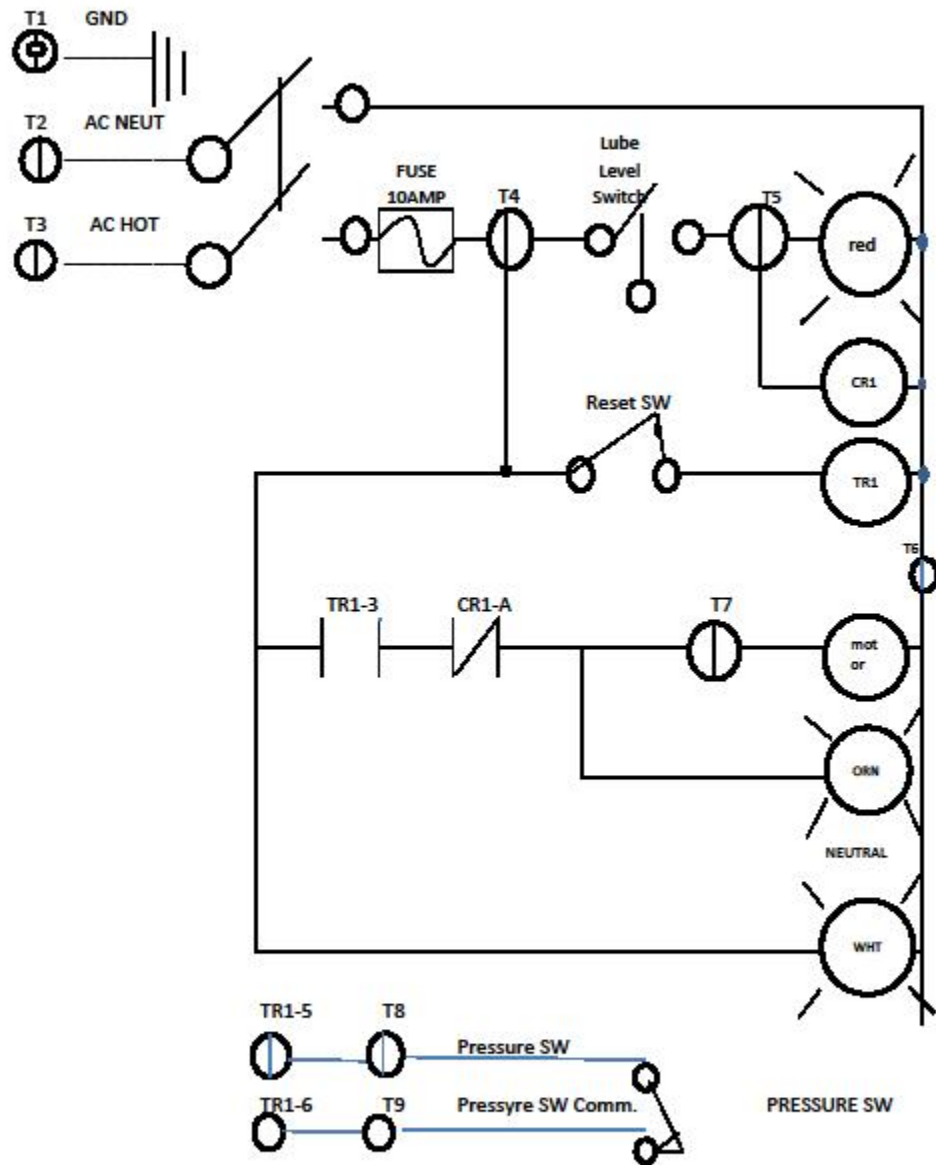

DIGILUBE PROGRAMMABLE LUBRICATION SYSTEM INSTALLATION / OPERATIONAL MANUAL

DL9000/24/24B POWER SUPPLY WIRE DIAGRAM

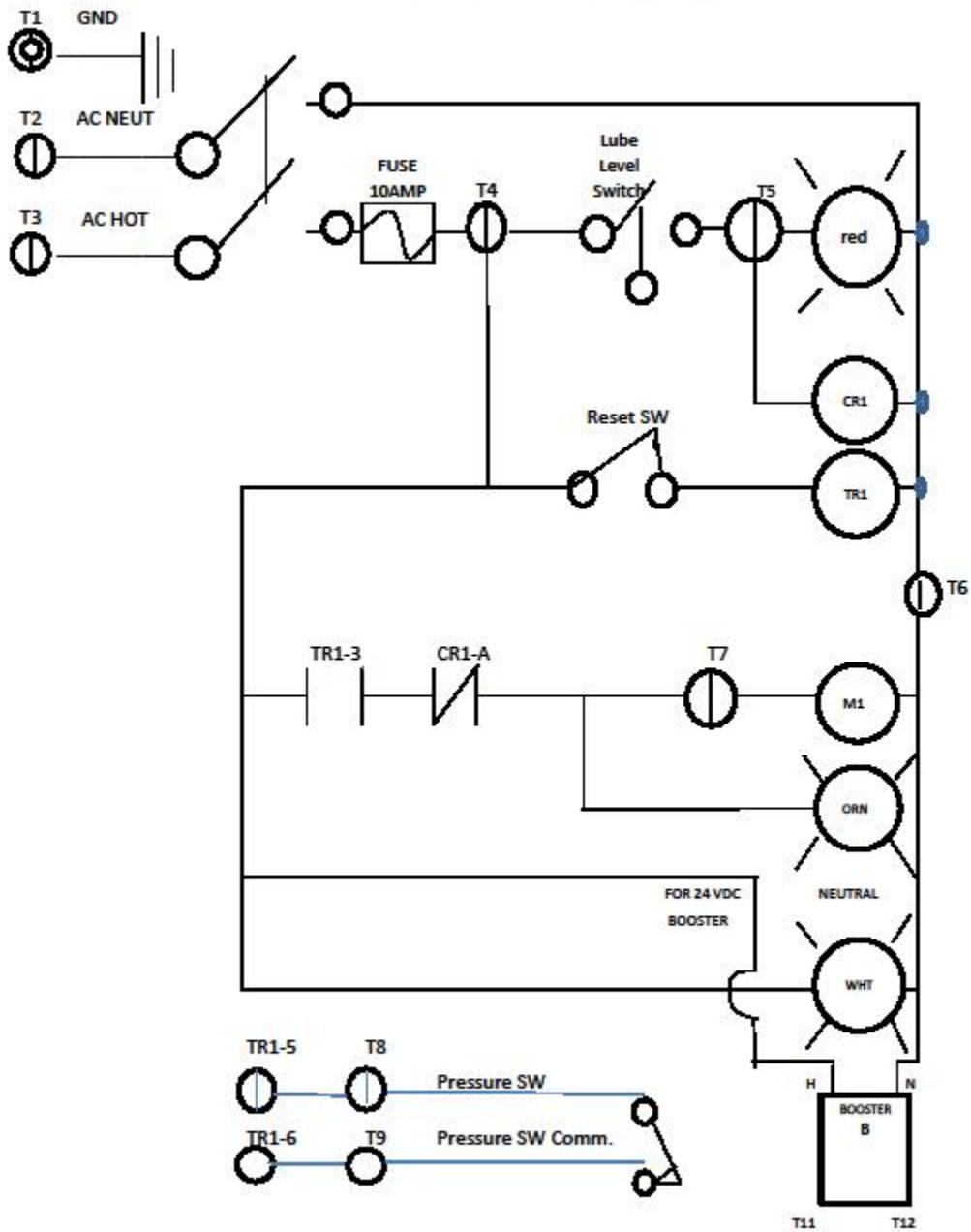

REV2 8/20/12